

1984 Vanagon

Volkswagen
Owner's
Manual



INTRODUCTION	2
OPERATING CONTROLS	4
VEHICLE OPERATION	45
VEHICLE CARE	52
DO-IT-YOURSELF SERVICE	72
TECHNICAL INFORMATION	86
GAS STATION INFORMATION	93
ALPHABETICAL INDEX	98

NOTES TO OWNER

Your new Volkswagen

is the result of many years of technical research and endurance testing. It is a sophisticated product of engineering, a vehicle designed for maximum efficiency and driving pleasure, a vehicle designed with your safety in mind.

Your vehicle may have all or some of the equipment described in this manual. Therefore, you may find explanations of equipment not installed in your vehicle.

Check with your authorized Volkswagen dealer on available options or accessories.

It has always been Volkswagen's policy to continuously improve its products. Volkswagen, therefore, reserves the right to make changes in design and specifications, and to make additions or improvements in its product, without incurring any obligation to install them on products previously manufactured.

Your Owner's Manual

contains a host of useful information. Read it before you drive your new vehicle. Pay particular attention to the "Break-in period hints" and to all points listed under "Vehicle operation".

Acquaint yourself with your vehicle's features and know how to operate it more safely. The more you know about your Volkswagen, the more you will enjoy driving it. For your own protection and longer service life of your vehicle, heed our instructions and warnings. Ignoring them could result in extensive damage or serious personal injury.

Text, illustrations and specifications in this manual are based on information available at the time of printing.

Please note that the items of equipment marked with an asterisk* may be standard on certain models but are only available as options on other models.

Your Warranty booklet

contains detailed information about the warranties covering your VW. These warranties are:

- Warranty for New Volkswagen Vehicles
- Warranty for New Volkswagen Vehicle Emission Control System (USA and Canada)
- Emissions Performance Warranty (USA only)
- California Emission Control System Warranty (California, USA only)

Your Maintenance booklet

explains how you can keep your Volkswagen in top driving condition by having it serviced regularly. Always have the Maintenance booklet with you when you take your vehicle to a VW dealer for service. Your Service Adviser will record each service.

If you sell your VW

the Owner's Manual, the Warranty booklet and the Maintenance booklet should be left in the vehicle to make the Warranty terms as well as all operating, safety and maintenance information available to the next owner.

If your change your address or if you bought this VW used

be sure to send in a "Notice of Address Change"/"Notice of Used Car Purchase" post card. This card can be found in the Warranty booklet or obtained from your VW dealer.

It is in your own interest that we can contact you should the need arise.**In Canada,**

this manual is also available in French. To obtain a copy, contact your dealer or write to:

Au Canada on peut se procurer un exemplaire de ce Manuel en français auprès du concessionnaire ou du:

Volkswagen Canada Inc.
Customer Assistance/
Assistance à la Clientèle
1940 Eglinton Ave. East
Scarborough, Ontario M1L 2M2

Operating your vehicle outside the U.S.A. or Canada

Government regulations in the United States and Canada require that automobiles meet specific emission regulations and safety standards. Therefore vehicles built for the U.S. and Canada differ from vehicles sold in other countries.

If you plan to take your vehicle outside the continental limits of the United States or Canada, there is the possibility that

- unleaded fuels for vehicles with catalytic converter may not be available;
- fuel may have a considerably lower octane rating. Improper fuel may cause engine damage;
- service may be inadequate due to lack of proper service facilities, tools or testing equipment;
- replacement parts may not be readily available.

Volkswagen cannot be responsible for the mechanical damage that could result because of inadequate fuel, service or parts availability.

Certain Volkswagen models are available for delivery in Europe under our tourist delivery and return shipment program.

For details consult your VW dealer or write to:

U.S.A. Volkswagen of America Inc.
Tourist Delivery
P. O. Box 3951
Troy, NJ 48007-3951

Canada Volkswagen Canada Inc.
Tourist Delivery
1940 Eglinton Avenue East
Scarborough, Ontario M 1 L
SM2

If you bought your vehicle abroad and want to bring it back home, be sure to find out about shipping and forwarding requirements, as well as current import and customs regulations first.

	page		page
1 – Air vents, left and right	35	13 – Fuses	76
2 – Headlight switch and thumb wheel for instrument illumination	32	14 – Turn signal/headlight dimmer switch lever	33
3 – Safety belt and brake warning lights	28	15 – Button for horn operation	
4 – Speedometer with trip odometer	30	16 – Steering lock/ignition/starter switch	24
5 – Warning/indicator lights	27	17 – Temperature switch for auxiliary heater*	38
6 – Clock with fuel gauge and water temperature gauge	30, 31	18 – Windshield wiper/washer lever	34
7 – Rear window defogger switch	32	19 – Secondary heat exchanger switch	37
8 – Emergency flasher switch	32	20 – For additional switch	26
9 – For additional switch		21 – Climate controls	36
10 – Air vents, left and right	35	22 – Air vents	35
11 – Ashtray	42	23 – Radio* (vehicles with factory fitted radio) have a radio instruction leaflet)	
12 – Loudspeaker grille		24 – Cigarette lighter	41
		25 – Glove compartment	42

*where applicable

OPERATING CONTROLS

KEYS

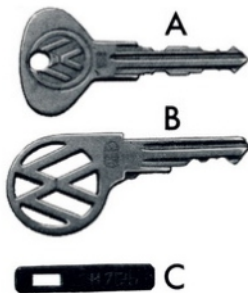

B25-252

Your Volkswagen comes with four keys:

- two keys A
- two keys B

Key A can be inserted into locks either way.

Key A is used for the ignition/steering lock, the doors and the rear luggage compartment lid.

Key B is provided for vehicles equipped with a lockable glove compartment.

Tag C gives the key number.

For your protection against theft:

■ Record the key number and keep it in a safe place, such as your wallet. Do not keep it in the vehicle.

■ If you should lose a key, provide your VW dealer with the key number to obtain a duplicate key.

■ **Do not leave your vehicle unattended with the key in the ignition lock. Take the key and lock the doors.**

The **buzzer** will sound when you open the driver's door with the key in the ignition lock. This is your reminder to remove the key and lock the doors.

WARNING

■ **Always remove the ignition key especially if children are left unattended in the vehicle.**

■ **Do not remove key from steering lock while you are driving or as the vehicle is rolling to a stop. The steering column is locked when you remove the key, and you will not be able to steer the vehicle.**

DOORS

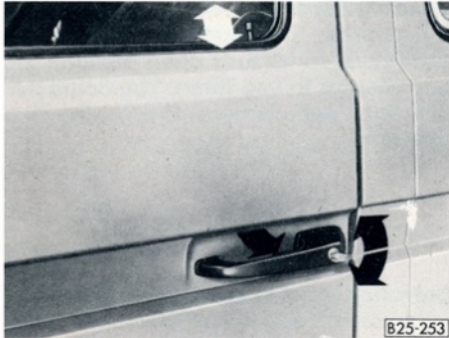

Front doors

To lock, unlock and open doors from the outside

- Lock and unlock the front doors by turning the key to the right or left.
- Open the doors by squeezing the trigger in the outer door handle.
- The passenger's door can be locked without a key. First depress the locking knob, then close the door.
- The driver's door can only be locked from the outside with the key. This precaution was taken to prevent locking the driver's door while the key is still inside the vehicle.

**To lock, unlock and open doors from the inside**

- To lock doors depress the locking knob. This will prevent opening the doors from inside and outside.

WARNING

To prevent inadvertent opening of a door from the inside, i. e. with small children in the car, drive with locked doors.

- To unlock doors raise the locking knob.
- To open doors pull the inside door handle after raising the locking knob.

OPERATING CONTROLS

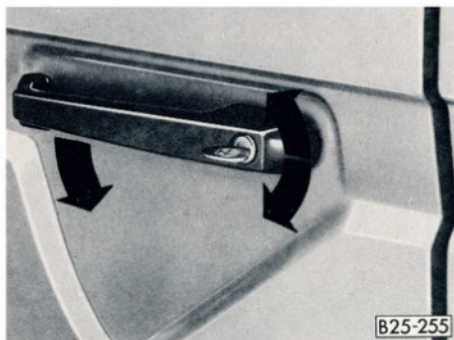

Sliding door

Always drive with a fully latched sliding door.

To open from the outside

- Unlock the door with the key.
- Then press the handle down and slide the door to the rear. The door is held in the fully open position by a catch.

WARNING

Make sure the catch is fully engaged. Otherwise, the door could slide forward by itself and cause injury to entering or exiting passengers.



To close and lock from the outside

- Press the handle down to release the catch. Slide the door forward until it is closed.

You can only lock and unlock the sliding door from the outside with the key.

To open from the inside

- Move the small sliding knob up and pull the handle back.

If the sliding door does not close on first try, operate the handle again and pull door back to its fully open position. Do not attempt to use force. You could jam the door and damage the sliding mechanism.

To close and lock from the inside

- Pull the handle forward to release the catch, close the door and move the small sliding knob down.

In the VANAGON Kombi and VANAGON Delivery Van

Cargo area

Make sure the cargo compartment floor area is loaded correctly, to permit unobstructed operation of the sliding door.

Do not transport people in the cargo area.

REAR LID

To unlock the rear lid, use the key A.

■ Insert key into vertical lock slot position and turn to left.

■ Press lock cylinder in and lift lid. The open hatchback will stay in position at any desired height.

■ To close, swing lid down.

■ Lock with key.

Be careful when loading or removing large objects. Sharp edged articles may damage the defogger wires in the rear window.

For safety reasons keep the rear lid locked at all times.

ENGINE COMPARTMENT LID

You have access to the engine compartment lid from inside the luggage compartment.

To open the lid, roll the floor covering out of the way and turn both lock handles to the left.

To close the lid, reverse the above procedure.

WARNING

Because of inherent hazards we do not recommend transporting objects larger than those fitting safely into the vehicle. Keep the rear lid closed while driving to prevent poisonous exhaust gas from being drawn into the vehicle.

OPERATING CONTROLS

WINDOWS

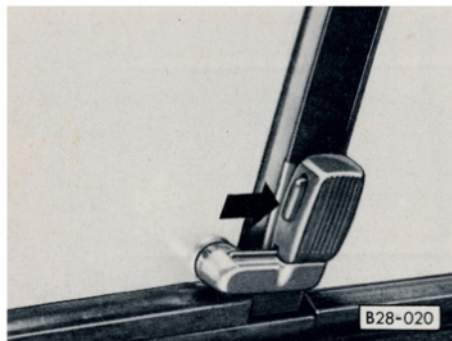

Vent windows*

- To open, press button in latch and turn the latch.
- To close, press vent window against seal and turn latch until button engages.

Door windows

Lower and raise the windows with the winders in the door panels.

WARNING

Do not put anything on or near the windows that may interfere with the driver's vision.

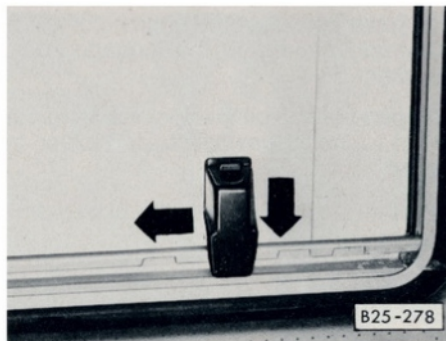

Sliding windows*

To open, press locking knob down and slide window open.

MIRRORS

Adjust the outside and inside mirrors before driving and after adjusting your seat to proper driving position. It is important for safe driving that you have good vision to the rear.

Outside mirrors

The outside mirrors are hinged and fold flat against the vehicle when struck from either direction.

Inside day-night mirror

You can adjust the day-night mirror from clear daylight visibility to non-glare visibility at night by moving the lever at the bottom of the mirror.

daylight driving – lever forward
night driving – lever down

SEATS

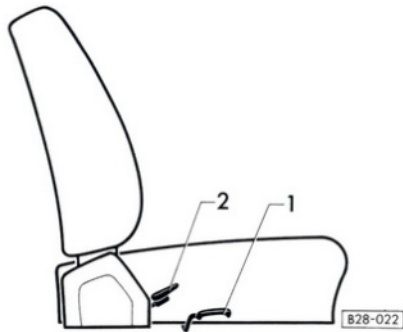

Seats in driver's cab

WARNING

Do not adjust seats while the vehicle is in motion. Your seat may move unexpectedly which could cause sudden loss of vehicle control or personal injury.

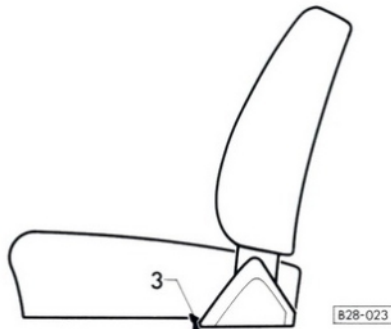

Vehicles with bucket seats

Seat adjustment (forward or backward)

The bucket seats can be adjusted individually.

- Pull up lower lever (1) at outboard side of seat.
- Slide seat to desired position.
- Let lever go and move seat slightly back and forth to make sure the seat is securely locked.

Seatback adjustment

The backrest is secured and cannot tilt forward accidentally.

- To adjust, take body weight off the backrest and push down lever (2) at hinge cover on right side of seat.
- Exert slight body pressure in the direction desired and let lever go to lock backrest in position.

WARNING

Front seat passengers should not ride in a moving vehicle with the seatback reclined. Safety belts only offer protection when the seatback is upright and belts are properly positioned on the body. Improperly positioned safety belts cause serious personal injury in an accident.

Removing bucket seats

- Stand outside vehicle, pull up lever (1) and slide seat all the way forward.
- Lift stop hook (3) up against spring-loading, hold there and slide seat past stop.
- Release stop hook and slide seat forward out of guide rails.

When reinstalling seat, reverse the above procedure. The stop hook (3) need not be lifted as the seat can just be pushed past the stop.

Vehicles with two-seater

Seat adjustment (forward or backward)

The two seater adjustment lever is located in front of the seat.

The adjustment procedure outlined for the front bucket seats also applies to the two seater.

The backrest adjusts at the same time the adjustment lever is operated.

Removing two seater

First remove bolts from the upper hinge on the backrest.

Then proceed as outlined for removal of the bucket seats.

Vehicles with swivel seats

The forward or backward adjustment procedure outlined for the front bucket seats also applies to the swivel seats.

Before turning the driver's swivel seat:

■ **Position shift lever in park (automatic transmission) or in first gear (manual transmission).**

■ **block wheels if necessary to prevent vehicle from moving.**

■ **release parking brake.**

WARNING

Swivel seats must be in forward facing position while driving.
Do not operate the locking lever of the swivel seat while the vehicle is in motion.

To swivel the seat, move seat slightly forward or open the door a crack. Then push down the locking lever in front of the seat. The **passenger** seat can be turned 180° to the **left** (half circle).

The **driver's** seat can be turned 90° to the right (quarter circle).

The seats will lock automatically at every turn.

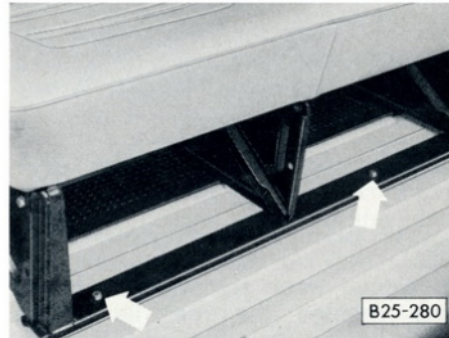
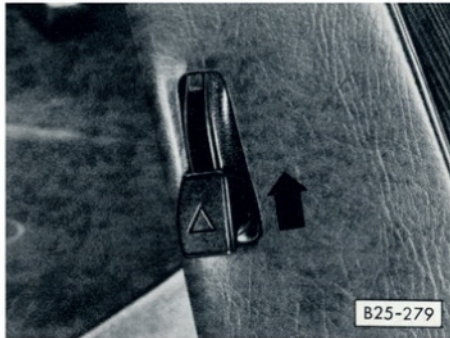

Seats in passenger compartment

In the 9-seater version (U.S. model only), the backrest of the first seat in the middle row can be tilted forward and out of the way for easy access to the rear bench. To disengage the lock of the backrest, pull up the lever on the side of the backrest.

WARNING

For your passenger's protection, the backrest lock must be engaged at all times while the vehicle is in motion.

Removing center seat bench

Remove the four bolts from under front and rear of seat bench, and take bench out of attachment rails.

To install the center seat bench, reverse the above procedure.

Note:

Keep the attachment rails clean.

Removing rear seat bench

The rear seat bench is secured with one bolt on each sidewall underneath the seat covering. Remove both bolts and take out the seat. **The backrest portion of the bench should not be removed.**

To install the rear seat, reverse the above procedure.

WARNING

Never drive the vehicle unless the seat benches are securely bolted down.

OPERATING CONTROLS

REAR SEAT/LUGGAGE COMPARTMENT

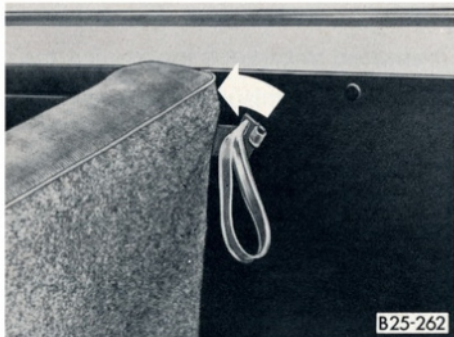

You can expand the luggage compartment load surface by folding the backrest of the rear seat bench down.

Folding backrest for rear seat bench

Unlock the backrest by pulling strap in driving direction. Fold backrest down until it rests on seat cushion.

The backrest will be locked automatically when returned to its upright position. Make sure the lap belts remain on top of the seat cushion, ready for use.

WARNING

Do not allow passengers to occupy the rear load surface while the vehicle is in motion.

When transporting luggage or other cargo, secure it in place to prevent such articles from shifting during a sudden stop.

Be careful when removing large objects through the rear lid. Sharp edged objects may damage the defogger wires in the rear window.

Keep the luggage compartment locked at all times to prevent unauthorized access to the vehicle.

WARNING

Because of inherent hazards we do not recommend transporting objects larger than those fitting safely into the vehicle. Keep the rear lid closed while driving to prevent poisonous exhaust gas from being drawn into the vehicle.

HEAD RESTRAINTS



■ For height adjustment grasp head restraint with both hands and pull up or push down.

WARNING

Do not drive the vehicle without the head restraint provided. Head restraints are designed to help reduce injuries.

SAFETY BELTS

WARNING

■ For your and your passenger's protection, use safety belts at all times while the vehicle is in motion.

■ Safety belts must be properly positioned on the body. Improperly positioned safety belts can cause serious personal injury in case of an accident. Therefore heed all of the following warnings and instructions.

■ A combination lap-shoulder belt should not be worn by a person less than 4'11" or 1.5 m in height, because it would not be in its most protective position and therefore may increase the possibility of injury in an accident.

■ Persons smaller than 4'11" or 1.5 m in height, and children who are able to sit upright by themselves, should use one of the rear seating positions and the lap belt provided.

■ Children who are not able to sit upright by themselves should use a child's seat.

■ A child's seat should not be fastened with the combination lap-shoulder belt as the belt will not provide the needed protection.

■ Do not strap in more than one person with each belt.

■ For maximum effectiveness, the lap belt should be worn low across the pelvic crest.

■ Do not wear shoulder part of belt under your arm or otherwise out of position. This would increase the possibility of serious injury in case of an accident.

■ Belts should not be worn twisted.

■ Do not wear belts over rigid or breakable objects in or on your clothing, such as eye glasses, pens, keys, etc. as these may cause injury.

■ Several layers of heavy clothing may interfere with proper positioning of belts.

■ Belts must not rub against sharp objects.

■ Keep belt buckles free of any obstruction that may prevent secure locking.

■ Make sure the belt of the unoccupied passenger seat is fully wound up on its retractor so that the belt tongue is in its stowed position. This reduces the possibility of the tongue becoming a striking object in case of a sudden stop.

■ Belts that have been subjected to excessive stretch forces in an accident must be replaced.

■ If belts show damage to webbing, bindings, buckles or retractors, they should be replaced.

■ If belts do not work properly, see your VW dealer.

■ Do not modify or disassemble the safety belts in your vehicle.

■ The belts must be kept clean as otherwise the retractors may not work properly (see also "Vehicle care", page 55).

■ Never bleach or dye safety belts.

■ Do not allow safety belts to retract until they are completely dry.

Combination lap-shoulder belts

Belt warning system

An audio-visual warning system is interconnected with the driver's safety belt.

Every time the ignition is turned on, the FASTEN BELTS warning light will come on for about 6 seconds as a reminder to buckle up. If the driver does not fasten the safety belt, the buzzer will also come on for the duration of this six second period. With the driver's door closed, the buzzer will go off as soon as the driver has buckled up.

Inertia reel retractor

The combination lap-shoulder belt with inertia reel locking mechanism adjusts automatically to your size and movements as long as the pull on the belt is slow.

Rapid deceleration during hard braking or a collision locks the belt. The belt will also lock when you drive up or down a steep hill or in a sharp curve.



- To fasten, grasp belt tongue and pull belt in continuous slow motion across your chest and lap.
- Insert belt tongue into buckle on in-board side of the seat. Push down until it is securely locked with an audible click. Pull belt to check.
- Pull shoulder section to make sure belt fits snugly across the hips.
- Belts should fit snugly across the pelvis and chest. Make sure any slack is wound on the retractor.

■ Do not wear shoulder part of belt under your arm or otherwise out of position. This would increase the possibility of serious injury in case of an accident.

■ To unfasten belt, push in release button on buckle. Belt will spring out of buckle.

To release a locked belt, lean back to take the body pressure off the belt.

■ To store lap-shoulder belt, allow belt to wind up on retractor as you guide belt tongue to its stowed position on doorpost.



- To fasten lap belt, grasp belt tongue on outboard side of seat, pull across pelvis and insert in inboard buckle.
- To unfasten belt, push in release marked PRESS in the buckle.

Always heed WARNINGS on page 15.

Lap belts

Seats in the passenger compartment are equipped with adjustable lap belts.

The belts should always be kept on top of the seat for ready use. Do not permit them to get caught under the seat.

■ To adjust the belt, hold the belt at a right angle to the belt tongue and pull the respective belt section in the desired direction. Adjusting is easier if cap and tongue of buckle are pressed together. Take up any slack by moving the slide on the belt.

BRAKES

Functioning of brake system

Your vehicle is equipped with a power assisted hydraulic dual circuit brake system with disc brakes at the front and self adjusting drum brakes at the rear. Both circuits function independently.

One brake circuit operates the front wheels and the other the rear wheels.

In the unlikely event of hydraulic failure of one circuit, **push the brake pedal down firmly and hold it in that position.** A mechanical linkage activates the second circuit, and you will be able to bring the vehicle to a safe stop.

WARNING

Failure of one brake circuit will impair the braking capability resulting in an increased stopping distance.

If one brake circuit has failed, the other will still operate. However, you will notice an increased pedal travel when you step on the brake. Should you encounter such experience, bring your vehicle safely to a full stop.

Avoid driving the vehicle and have it towed to the nearest VW dealer or qualified workshop.

Brake pedal

WARNING

■ **The movement of the brake pedal must never be obstructed by a floor mat or any other object. In case one of the two brake circuits fails, increased pedal travel is required to bring your vehicle to a full stop.**

■ **Make sure that the size of your floor mat does not hamper the movements of either brake, clutch or accelerator pedals in any way.**

■ **Secure the floor mat against sliding into positions that could interfere with the safe operation of your vehicle.**

■ **Do not “ride the brakes” by resting your foot on the pedal when not intending to brake. Overheating and wear of the brakes is the result.**

■ **Before descending a steep grade, reduce speed and shift transmission into a lower gear or driving position to control speed. Do not ride the brake or hold the pedal down too long, or too often. This could cause the brakes to get hot and not function properly.**

Brake operation and brake warning light

Make it a habit to check the operation of your brakes before driving. The brake warning light will light up while the engine is cranking and the parking brake is pulled or one of the brake circuits should fail. For more details see “Brake warning light” on page 26.

Keep in mind that the braking distance increases very rapidly as the speed increases. At 60 mph or at 100 km/h, for example, it is not twice but four times longer than at 30 mph or at 50 km/h. Tire traction is also less effective when the roads are wet and slippery. Therefore, always maintain safe distance.

Brake booster

The brake booster assists braking only when the engine is running. When the vehicle is moving while the engine is not running, more force on the brake pedal is required to bring the vehicle to a stop.

Moisture or road salt on brakes affects braking

WARNING

Driving through water may reduce tire traction. Moisture on brakes from road water, car wash, or coating of road salt may affect braking efficiency. Cautiously apply brakes for a test. Brakes will dry and salt coating will be cleaned off after a few cautious brake applications.

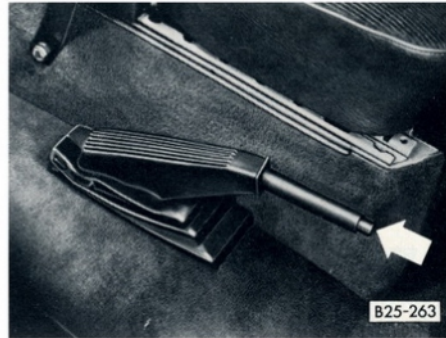

Brake wear

Our automobiles have excellent brakes, but they are still subject to wear, depending on how the brakes are used. Have the brake system inspected at the intervals recommended in your Maintenance booklet.

New brake pads or linings

Brake pads or linings may not have the highest possible braking efficiency when new. Therefore allow for longer braking distance during the initial 100 to 150 miles or 150 to 250 kilometers.

Parking brake lever

The parking brake lever is located between the front seats.

- To set the parking brake, pull the lever all the way up. With the ignition on, the brake warning light will light up.
- To release the parking brake, pull the lever slightly up, depress the release button (arrow), and then push the lever all the way down. When the parking brake is fully released, the brake warning light will go out.

WARNING

- Release the parking brake fully. A partially engaged brake will overheat the rear brakes, reduce their effectiveness and cause excessive wear.
- Always set the parking brake when parking your vehicle. Move the selector lever to "P" (Automatic transmission) or move the gearshift lever to "R" or "1" (Manual transmission). On hills also turn the wheels toward the curb.

OPERATING CONTROLS

MANUAL TRANSMISSION

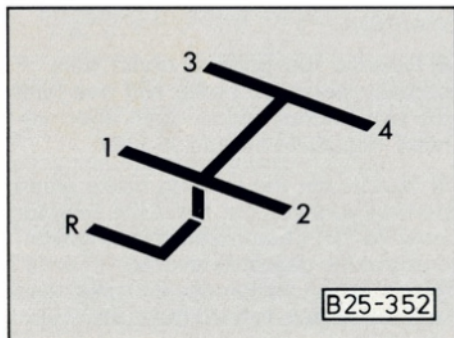

Gearshift lever

Start engine with gearshift lever in Neutral, clutch pedal depressed.

Always depress the clutch pedal fully when changing gears. Do not hold the vehicle on a steep hill with the clutch pedal partially depressed. This may cause premature clutch wear or damage.

Resting your hand on the shift lever knob while driving will cause premature wear in the transmission.

The Manual Transmission is fully synchronized in the forward gears. The forward gears and the reverse gear are arranged as illustrated.

Reverse

Only shift into Reverse when the vehicle is not moving.

To engage Reverse, move lever to left, press down, move further to left and then push forward. Especially after some driving, depress the clutch pedal fully and rest the shift lever in Neutral for a few seconds before shifting into Reverse.

Back-up lights go on when you engage Reverse gear with ignition on.

AUTOMATIC TRANSMISSION

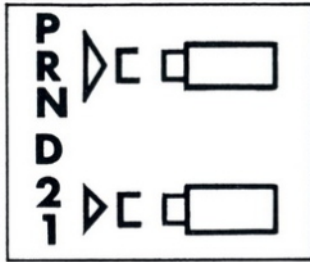

Selector lever positions

P – Park

Engage Park only when the vehicle is stationary. Therefore when parking your vehicle, apply the parking brake first, and then move the selector lever completely to position P. **To do this depress the button in the handle of the selector lever and push it through R to P.** The transmission is then mechanically locked.

Shift out of the Park position, before releasing the parking brake.

When the vehicle is parked on a steep hill, shifting out of Park may be a little harder. This is due to the vehicle's weight exerted on the transmission.

R – Reverse

Reverse position should be selected only when the vehicle has come to a full stop and the engine is running at idle speed.

Before you move the selector lever to the reverse position you have to depress the push button in the handle of the selector lever.

N – Neutral

Shift to this position for standing with brakes applied.

Do not use neutral for coasting downhill. Coasting downhill with the transmission in neutral and the engine not operating will result in damage to the automatic transmission.

D – Normal driving position

Position D is for normal city and highway driving. It ranges from zero to top speed, and all three gears shift automatically, depending on the speed.

2 – Position for hilly stretches

This position is to be used for mountain driving or slow driving, and also when you want to make use of engine's braking effect.

In "2", only the first and second gears will engage automatically. Therefore, **only shift down into position "2" when vehicle speed is below 54 mph or 87 km/h.** It is not necessary to let up on the accelerator.

1 – Position for steep hills

This position is to be used for mountain driving or slow driving. It also provides for maximum engine braking effect. **To engage this gear depress the push button in the handle of the selector lever first.** In "1" the transmission will stay in first gear and will not upshift. **Only shift down into "1" when the speed is below 33 mph or 53 km/h.**

WARNING

Do not shift to a lower driving position until vehicle speed has dropped below specified limits. Engine speed will suddenly increase and may cause engine damage and loss of vehicle control.

Driving the automatic transmission

Observe the speed ranges for the break-in-period – see page 47.

Starting the engine

The selector lever must be in **Neutral** or **Park**. As long as one of the driving positions is engaged a safety switch prevents the engine from being started.

Emergency starting

Your VW with Automatic Transmission cannot be started by pushing or towing. If engine does not start because of discharged battery, the vehicle can be started with jumper cables. Refer to "Emergency starting with jumper cables". Should the engine fail to start consult your nearest VW dealer.

Selecting a driving position

WARNING

■ Apply the parking brake or foot brake before selecting a driving position when the vehicle is not moving.

When the selector lever is in a driving position, the vehicle may creep even at idle speed. Therefore, do not release the parking brake or foot brake until you are ready to move.

■ Do not accelerate while selecting a driving position. At this time the engine must run at idle speed so that no undue stress will be placed on the automatic clutches in the transmission.

■ Never have one position engaged when checking in the engine compartment. Make sure the selector lever is in the P position with the parking brake applied. Otherwise, any increase in engine speed may set the vehicle in motion, even with the parking brake applied.

■ Never shift into Reverse (R) or Park (P) when the vehicle is in motion.

■ Do not remove the key from the ignition steering lock until you have parked the vehicle, because removal of the key locks the steering wheel.

■ If the selector lever is unintentionally moved into Neutral (N) while driving, take your foot off the accelerator pedal and wait until the engine speed has dropped to idling before selecting a driving position.

Do not release the brake before you are prepared to move, because power is transmitted to the wheels as soon as a driving position is engaged.

Maneuvering

When alternating between forward and reverse – for instance, while maneuvering the vehicle into a tight parking space – only shift when the vehicle has come to a full stop and the engine is running at idle speed.

Stuck in snow, mud or sand

When alternating between forward and reverse in an effort to free the vehicle, depress the accelerator pedal slightly while the transmission is in gear, and release the accelerator pedal while shifting. Do not race the engine and avoid spinning the wheels. **Do not repeat “rocking” back and forth with wheels spinning at high engine speed and heavy throttle, as serious damage may be caused to the automatic transmission and other critical parts.**

Kick-down device

The kick-down device gives maximum acceleration. When the accelerator pedal is pressed right down past the full throttle position, depending on road speed and engine speed, either the upshift is delayed (forced throttle) or the box changes down into the next lower gear.

WARNING

Be careful when using the kickdown on slippery roads. Rapid acceleration may cause skidding.

Stopping

- When stopping briefly, at a traffic light for example, it is not necessary to move the selector lever to Neutral. Simply apply the brakes. To start again release brake and accelerate.
- The driving positions must never be used for holding the vehicle at rest uphill. Always use your foot brakes when stopped on inclines.

WARNING

- **Never get out of the driver's seat when the engine is running and the selector lever is not in the P position.**
- **If you must leave the vehicle move the selector lever to P and apply parking brake.**

Towing

If the vehicle has to be towed at any time, you must read the instructions in the section “Emergency towing” on page 93.

OPERATING CONTROLS

STEERING LOCK / IGNITION / STARTER SWITCH

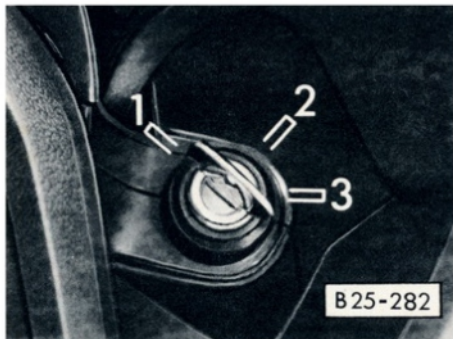

The steering is equipped with an antitheft ignition lock.

Switch positions

1 – Ignition off/steering can be locked. Pull out the key and turn steering wheel until it locks.

WARNING

Never remove key from steering lock or turn key off while the vehicle is moving. The steering wheel will lock, causing loss of control.

- 2 – Ignition on/steering free.
If it is difficult to turn the key from position 1 to 2, gently move the steering wheel until the key turns freely.
- 3 – Starter engages.

Key returns to Pos. 2 as soon as it is released.
“Starting procedures” see next pages.

In position 3, the power supply to headlights, windshield wipers, blower motor and rear window defogger is temporarily interrupted to conserve battery power.

Before the starter can be operated again the key must be turned back to position 1.

The non-repeat lock in the ignition switch prevents the starter from being operated when engine is running as this could damage the starter.

In position 2 and 3 several warning/indicator lights will come on. Refer to “Warning/indicator lights” for details.

Buzzer

If you leave the key in the ignition/steering lock, the buzzer will sound when the driver’s door is opened. This is your reminder to remove the key.

STARTING PROCEDURES

WARNING

- Fasten safety belts before driving off.
- Never start or let the engine run in an enclosed, unventilated area. Exhaust fumes from the engine contain carbon monoxide, which is a colorless and odorless gas. Carbon monoxide can be fatal if inhaled.
- Never leave engine idling unattended. An unattended vehicle with a running engine is potentially hazardous.
- Do not park or operate the vehicle in areas where the hot exhaust system may come in contact with dry grass, brush, fuel spill or other flammable material.
- Never leave engine idling. When starting engine, be ready to drive off immediately. Maintain moderate speed until engine is warm.

Automatic Transmission

Engine will only start with selector lever in Neutral or Park.

Manual Transmission

Start with gearshift lever in Neutral, clutch pedal depressed, so that the starter only has to crank the engine.

Starting gasoline engine

- Do not depress accelerator pedal when starting. This applies at any outside temperature.
- As soon as the engine starts, release the ignition key.
- If the engine does not start the first time or stalls, turn the ignition off and restart. Depress the accelerator pedal slowly during the second starting attempt.
- Operate the starter for no more than 10 seconds.
- Allow about 1 minute between each starting attempt.

STOPPING ENGINE

Applies to all engines:

- Turn key back to position 1.

Do not stop engine immediately after hard or extended driving. Keep engine running at increased idle for about two minutes to prevent excessive heat build-up.

WARNING

- Before you check anything in the engine compartment, let the engine cool down. Hot components can burn skin on contact.
- The radiator fan switches on automatically when the coolant reaches a certain temperature and continues to run (even with ignition off) until the coolant temperature drops.

OPERATING CONTROLS

WARNING / INDICATOR LIGHTS

Your vehicle is equipped with several important indicator and warning devices to monitor the continued reliable operation of your vehicle. Familiarize yourself with these devices so if one should come on you know what to do. Failure to heed the following warnings may result in serious damage.

WARNING

■ Whenever stalled or stopped for repair, move the vehicle a safe distance off the road, stop the engine and turn on the emergency flasher – see page 30.

■ Before you check anything in the engine compartment, let the engine cool down. Hot components can burn skin on contact.

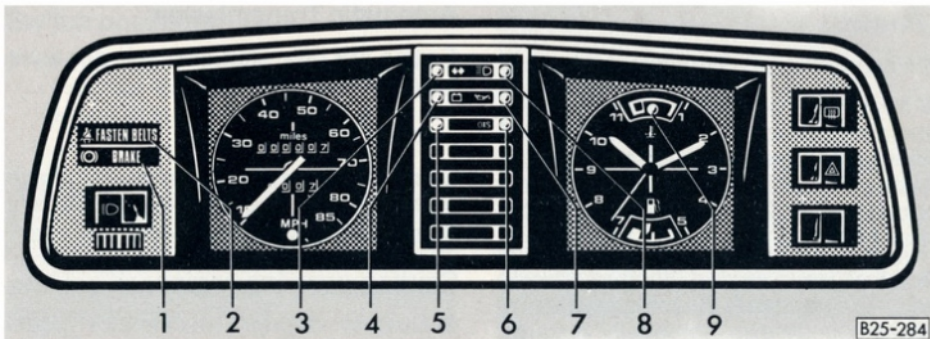

1 – Brake warning light



The light comes on while the engine is cranking. It goes out after the engine is started and the parking brake is fully released. This is your assurance that the brake warning light functions properly.

If the brake warning light does not light up while cranking the engine or setting the handbrake, there may be a malfunction in the electrical system. In this case, contact your VW dealer.

WARNING

If the brake warning light lights up when you apply the brakes while driving, one of the two brake circuits may have failed. First make sure the parking brake is fully released.

The brake warning light does not indicate brake fluid level in the reservoir. Check the fluid level between regular maintenance services.

For detailed information see “**Brakes**” on page 18.

2 – Safety belt warning light



Refer to “**Safety belts**” on page 15 for details.

3 – Turn signals

Refer to “Turn signal/headlight dimmer switch lever” on page 31 for details.

4 – Alternator warning light

This light comes on when the ignition is turned on and goes out after the engine is started. If the light does not go out after starting and revving-up the engine momentarily or lights up while driving, there may be a malfunction in the electrical system or the V-belt to the alternator may be loose or broken.

In this case, **turn the engine off** and contact your VW dealer.

5 – For additional light

6 – Service reminder light*

The following lights will come on when the ignition is turned on and should go out after the engine is started.

If the lights come on and stay on, read your odometer. The time has come to

take your vehicle to your VW dealer for the scheduled emission control maintenance service.

Exhaust gas recirculation light

comes on every 15,000 miles or 24,000 km.

Oxygen sensor light

comes on every 30,000 miles or 48,000 km.

7 – Oil pressure warning light

When the ignition is turned on, the oil pressure warning light comes on for a bulb check. It should go out after the engine has started.

If the oil pressure warning light does not light up when turning the ignition on or if it does not go out after starting the engine, contact your VW dealer immediately.

STOP AT ONCE if the oil pressure warning light comes on while driving. (Brake warning light also comes on due to design

EGR

OXS

of electrical system. In case of brake failure, only brake warning light will come on.)

Turn the engine off!

The oil pressure warning lights is not an indicator for low engine oil level. To check the oil level, always use dipstick (see page 58).

Check the engine oil level to make sure you have enough oil. If in doubt about the cause do not drive on but contact nearest VW Dealer.

An occasional flickering of the oil pressure warning light when the engine is idling after a long high-speed trip is no cause for concern if the light goes out upon acceleration.

8 – High beam

Refer to “Turn signal/headlight dimmer switch lever” on page 31 for details.

9 – Water temperature

Refer to “Water temperature gauge” on page 28 for details.

*where applicable

OPERATING CONTROLS

INSTRUMENTS

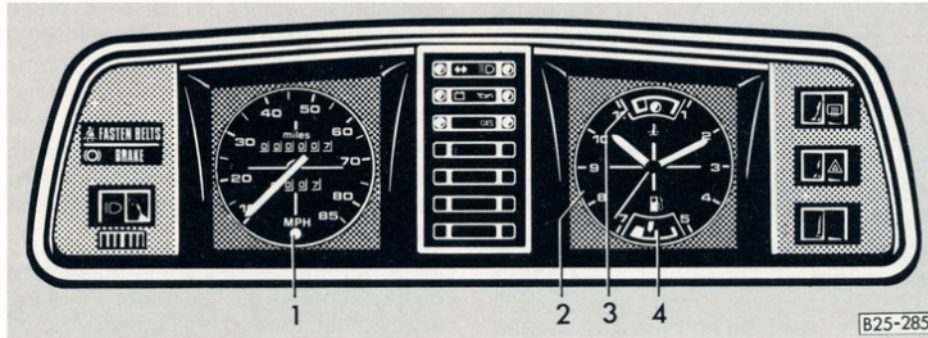

1 – Speedometer dial

The **speedometer** indicates road speed. The **odometer** indicates the distance driven.

U.S. models: Miles
Canada models: Kilometers

To record a distance, reset the **trip odometer** to zero by pressing the button. The last digit in red indicates 1/10 of a mile or kilometer.

2 – Clock*

To set the electric clock, depress the knob in the dial center and turn.

3 – Water temperature gauge

The needle in the water temperature gauge will indicate the temperature of the coolant shortly after the ignition is switched on.

Engine operating temperature will vary with climate, traffic conditions and engine load. Maintain moderate speed until the engine has warmed up.

When the engine is working hard and in stop-and-go-traffic, the needle can show a very high temperature, but this is not serious as long as the warning light does not flash.

Warning light

For a bulb check the red light in the water temperature gauge will flash for about 3 seconds when the ignition is turned on.

If the light flashes while driving, the engine may be overheated because of low coolant level or V-belt damage. Move the vehicle a safe distance off the road, stop the engine and depress the emergency flasher switch.

The fan should be operating when the warning light is on (listen for fan, located in front of car behind grille).

WARNING

■ Before you check anything in the engine compartment let the engine cool down. Hot components can burn skin on contact.

■ Be careful if you have to remove the cap from expansion tank. Protect your hands, arms and face against scalding. Use a thick rag and open the cap carefully one turn to allow excess pressure to escape before removing the cap.

If a visual check shows that coolant level and V-belt are normal, but the warning light continues to flash, contact your nearest dealer to have the cause located and corrected.

For more details see "Cooling system" on page 63.

Do not install accessories (fog lights or insect screens, for example) on top of the front bumper. They may restrict engine cooling.

4 – Fuel gauge

The needle in the fuel gauge will indicate the fuel level in the tank shortly after the ignition is switched on.

The fuel tank capacity is 16 gal/60 liters.

When the needle reaches the red area at the bottom there is a reserve of about 2.6 U.S. gal. or 10 liters of fuel left in the tank. Time to refuel.

OPERATING CONTROLS

SWITCHES

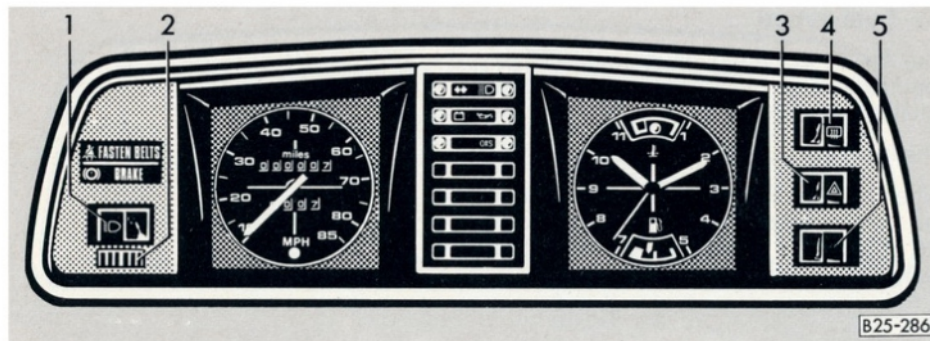

WARNING

Move the vehicle a safe distance off the road when stalled or stopped for repairs. Do not park or operate the vehicle in areas where the hot exhaust system may come in contact with dry grass, brush, fuel spill or other flammable material.

1 – Headlight switch



Depress the rocker switch to the first stop to turn on the parking, side marker, license plate, tail and instrument lights.

Depress the switch to the second stop to turn on the headlights (ignition on).

To conserve battery power, the headlights will go out automatically when the ignition is turned off or when the engine is started.

2 – Instrument illumination

Turn the thumb wheel below rocker switch to adjust the brightness of instrument lights.

3 – Emergency flasher switch



The emergency flasher works independently of the ignition switch position.

If your vehicle is disabled or parked under emergency conditions, depress the switch to make all four turn signals flash simultaneously. The warning light in the rocker switch flashes, too.

When the headlight switch is operated, the emergency flasher switch glows with reduced brightness for easy recognition in the dark. When the emergency flasher is not in operation, the brightness of the light can be adjusted together with the instrument panel illumination.

4 – Rear window defogger switch

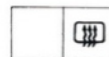

The rear window defogger works only with the ignition on.

The rear window defogger – together with the flow through ventilation – will help to keep the inside of the rear window clear of condensation and frost in the winter.

Depress the switch to turn on the rear window defogger.

The control light in the switch will light up to remind you that the defogger is switched on. After the rear window has been cleared, switch off the rear window defogger to avoid unnecessary drain on the battery.

5 – For additional switch

TURN SIGNAL / HEADLIGHT DIMMER SWITCH LEVER

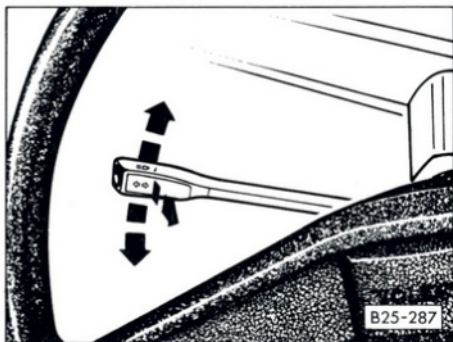

The lever on the left side just behind the steering wheel is for the turn signal/headlight dimmer switch.

Turn signals

The turn signal indicator light flashes when you operate the lever (ignition on).
Lever up – right turn signal
Lever down – left turn signal

The turn signals are cancelled automatically when you have completed a turn (like driving around a corner), and the steering wheel returns to the straightahead position.

If a turn signal fails, the indicator light flashes about twice as fast. A light bulb may have to be replaced.

Lane changer

To indicate your intention when changing lanes on expressways, move the lever up or down just to the point of resistance. The lever will return to the OFF position when released.

Headlight dimmer

With headlights on, you can switch to either high or low beam by pulling the lever toward the steering wheel past the point of resistance. When high beam is on, the indicator light will light up.

Headlight flasher

With headlights on, or off, you can signal with your headlights (in lieu of horn) during daylight, by repeatedly pulling and releasing the lever just up to the point of resistance.

OPERATING CONTROLS

WINDSHIELD WIPER AND WASHER LEVER

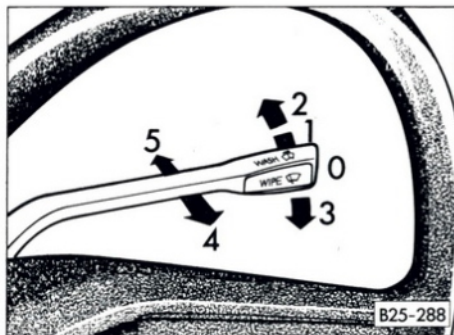

The lever on the right side behind the steering wheel is for the windshield wiper and washer. It only works with the ignition on.

Windshield wipers

The windshield wipers can be operated at the following speed:

Lever up to position 1 – low speed

Lever up to position 2 – high speed

Lever down to position 3 – intermittent wiping*

In position 3 the wipers sweep the windshield approximately every six seconds.

Lifting the lever slightly without engaging the first stop allows the wipers to operate for as long as the lever is held in this position. The wipers will stop when the lever is released.

Always loosen blades frozen to glass before operating wipers to prevent damage to the wiping system.

Windshield washer

To spray washer fluid on the windshield, pull the lever toward the steering wheel (position 4) from any selected wiping position.

If you pull the lever from the 0-position, washer fluid is sprayed on the windshield and the wipers work. When lever is released, washer stops immediately, but wipers will continue to run several times to dry the windshield.

Rear window wiper and washer*

Push lever to position 5 and release. The wiper will operate two or three times.

Push lever to position 5 and hold. Both, wiper and washer will operate.

Release lever. The washer operation stops instantly and wiper stops after two or three sweeps.

WARNING

■ **Check wiper blades periodically.** Worn or dirty blades reduce visibility, making driving hazardous. Loosen blades frozen to glass before operating wipers.

■ **Clean all windows, windshield and wiper blades regularly to remove road film and carwash wax buildup.** Use an alcohol base cleaning solution and a sponge or soft cloth. Dry glass with a chamois.

■ **Avoid running the wiper blades over a dry windshield to prevent scratching the glass.** Spray on washer fluid first. A scratched windshield will reduce visibility.

*where applicable

VENTILATION / HEATING

WARNING

■ Familiarize yourself thoroughly with the proper use and function of the ventilation/heating and defogging/defrosting system.

■ For safe driving it is extremely important that you follow the operating instructions in this manual. If in doubt, consult your VW dealer.

■ Maximum heating output and fast defrosting can be obtained only after the engine has reached operating temperature.

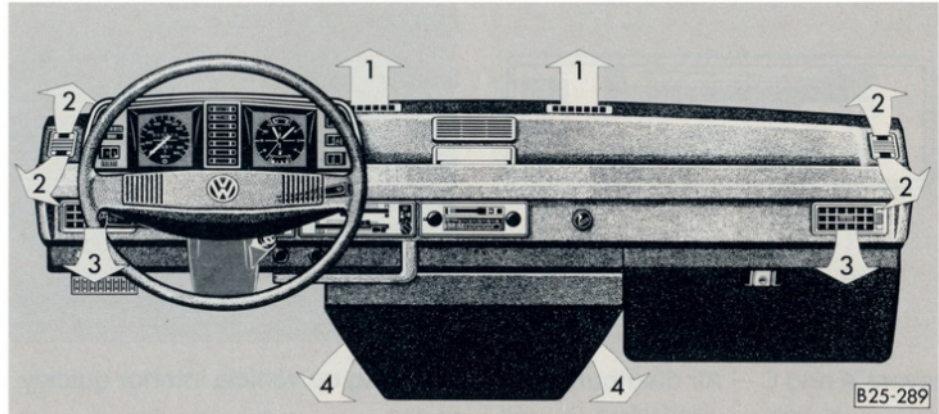

Air outlets

Heater or outside air flow from outlets 1, 2, 4 and footwell outlets in passenger compartment*, according to control lever positions.

Outside air flow from outlets 3 and roof outlets in passenger compartment*.

The side dashboard outlets 3 are individually adjustable –
 side lever down – vent open
 side lever up – vent closed.

Adjust air flow direction sideways or up and down with center lever.

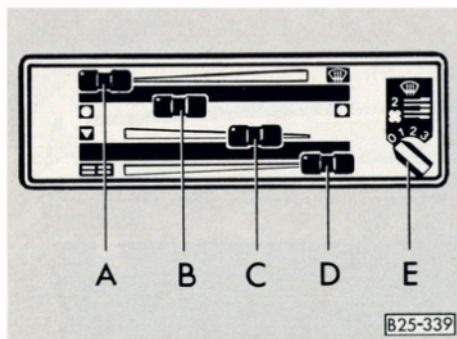

Levers A and C – Air distribution

Lever A at right – windshield (1) and side window (2) outlets open.

Lever C at left – footwell outlets under dashboard (4) and footwell outlets in passenger compartment* open.

Lever B – Temperature control

To increase heat – slide lever to right.
To decrease heat – slide lever to left.

Lever D – Roof outlets in passenger compartment*

To increase outside air flow – slide lever to right.
To decrease outside air flow – slide lever to left.

Fan control switch E

The air volume can be regulated with three fan speed settings.

Defogging and defrosting windshield and side windows

■ Slide all control levers to the extreme right and turn fan control switch E to speed setting 2.

■ The fan control switch for the secondary heat exchanger should be OFF.

Warming up vehicle interior quickly

■ Slide levers A, B and D to extreme right.

■ Slide lever C to extreme left.

■ Close air outlets 3.

■ Turn fan control switch E to speed setting 2.

Warming up vehicle interior normally

Once the windshield and side windows are clear and the vehicle interior is warm, you may want to set the controls as follows:

■ Slide lever A to the left.

■ Slide lever B to desired temperature setting. www.vag-klassik.de

■ Slide lever C toward center.

■ Turn fan control switch E to speed setting 1.

Outside air ventilation

With lever B at extreme left, outside air is emitted from all open outlets. When lever B is moved toward the right, outside air is emitted from open dashboard vents (3) only.

Hints

■ All operating controls, except fan control switch E and fan control switch for the secondary heat exchanger can be adjusted to any intermediate position.

■ Stale air is drawn out of the vehicle interior through vents on the inside front door panels. The vents can be opened or closed by sliding the lever forward or rearward.

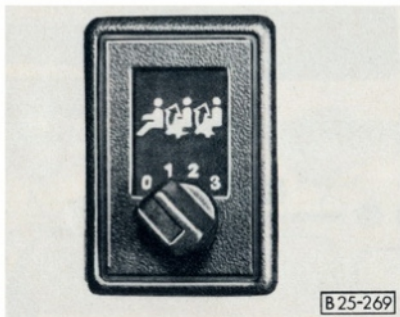

Secondary heat exchanger for passenger compartment*

This heat exchanger is located under the rear seat bench. The air volume can be regulated with the 3-speed fan control switch on the instrument panel (see above illustration).

During the warm months of the year, the secondary heat exchanger can supplement the outside air flow-through ventilation system.

To prevent warm air flow from reaching the footwells, the heat exchanger valve must be shut off.

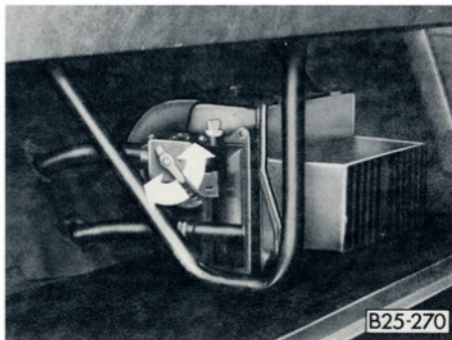

To gain access to the valve –

- Grasp upper edge of kick panel under rear seat bench and pull out.
- To open valve – pull lever forward.
- To close valve – pull lever rearward (see above illustration).
- Reinstall kick panel securely.

*where applicable

OPERATING CONTROLS

AIR CONDITIONER*

WARNING

- Familiarize yourself thoroughly with the proper use and function of the air conditioning system.
- For safe driving it is extremely important that you follow the operating instructions in this manual. If in doubt, consult your VW dealer.

The air conditioning unit is installed under the roof of the driver's cab. Ten air outlets permit interior cooling throughout the vehicle.

Three climate control switches are located just above the center of the windshield for easy reach.

The unit operates on the air recirculation principle. Air is sucked in through the two large air intake grilles at the rear portion of the unit.

Because the air conditioner is not normally used at low ambient temperatures it is designed to operate only when outside temperature is above 41° F or + 5° C.

* where applicable

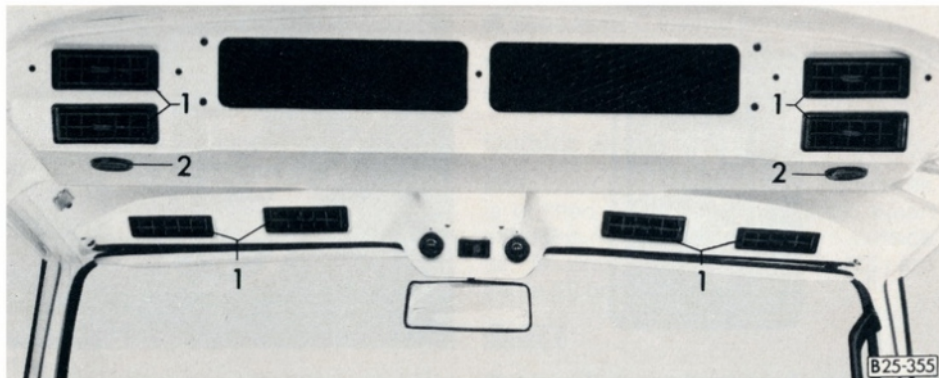

When the air conditioner is on, temperature as well as humidity inside the vehicle is controlled. During high outside humidity you can prevent windshield and windows from fogging by setting the controls accordingly.

Maximum cooling is maintained with standard heating/ventilation controls turned off and the windows closed.

However, when the vehicle interior is very hot from standing in the sun, open a window for a few minutes to permit hot air to escape.

Air outlets

- 1 – These air vents can be adjusted or closed completely.
 - Tilt air vent housing to direct air flow up or down.
 - Turn thumb wheel to direct air flow sideways.
 - To open six outlets, position thumb wheel in center of vents.
 - To close air outlets, turn thumb wheel to extreme right or left.
- 2 – These air vents can be adjusted but not closed.
 - Direct air flow by swiveling the vent housing.

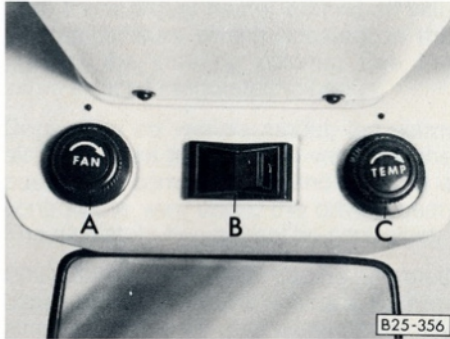

Operating controls

A – Fan switch

- Adjust air volume by turning switch knob or either one of the three speeds.
- With fan switch knob OFF, the air conditioner will not operate.

B – Air volume preselect

- With this switch you can preselect blower motor (rpm) speeds.
- Depress right half of rocker switch for high speed.
- Depress left half of rocker switch for low speed.

The operation of switch A and B result in a six-speed air volume control combination.

C – Temperature control switch

- Turn switch knob left for cooler air.
- Turn switch knob right for warmer air.

With switch knob in OFF position, the thermostat switch in the air conditioning unit is turned off. There will be outside air ventilation but no air cooling takes place.

Operating hints

Comfort cooling

- Turn fan switch A to speed setting “1” or “2”.
- Depress left half of rocker switch B.
- Turn temperature control switch C to desired position.
- Adjust air outlet vents as desired.

Maximum cooling

- Turn fan switch A to extreme right.
- Depress right half of rocker switch B.
- Turn temperature control switch to extreme right.
- Adjust air outlet vents as desired.

Malfunctions

If the unit does not operate

- Outside temperatures may be below 41° F or + 5° C.
- The air conditioner fuse may have blown. Turn the unit off and check fuse. See page 76 for fuse panel location.

If the engine overheats

- High load operating conditions at extremely high outside temperatures (for example).
- Turn the air conditioner off and wait until the coolant temperature reaches a normal level.

Should you suspect that your air conditioner is damaged, have it checked promptly for leaks or other damage. Leaks must be sealed immediately since loss of refrigerant may result in serious damage to the air conditioning system.

General hints

If water drips under the vehicle

When outside temperature is high and the air very humid, condensed water can drip off the evaporator under the vehicle. This is normal and does not indicate a leak.

Payload reduction

The weight of the air conditioner installed in your vehicle reduces the vehicle's load carrying capacity. For weight information, see sticker on left door post.

Maintenance

The condenser should be checked periodically for cleanliness. If clogged with dirt or insects, the condenser should be washed down with water.

After the winter months and before extended summer usage, the air conditioner should be checked and, if necessary, serviced by your VW dealer.

AUXILIARY HEATER*

Turn the auxiliary heater on and off with the temperature switch, located on the right of the steering column. Use the same switch to regulate the heat.

Depending on vehicle model, the warm air flows from the footwell vents for the passenger compartment and/or from a controllable vent under the driving seat. The air distribution cannot be controlled.

While driving, the heater can be operated continuously. When the engine is not running, the heater will shut off automatically after 10 minutes to save battery power.

The auxiliary heater is running on fuel from your fuel tank. Fuel consumption varies according to operating conditions and heat output (approx. 1 US qt or one liter per hour).

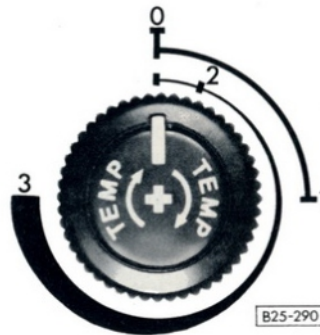
**Switch knob positions**

0 – Heater off.

Engine stationary

0 – 1 Push knob in and turn clockwise. When clockwork in the temperature regulating switch is running, the heater will be operational, and the control light in the switch knob will come on.

Engine running

2 – Heater is operational and switch knob control light is on.

2 – 3 Temperature adjustment range.

Engine stationary/ignition off

Heater on:

From position 0, push knob in and turn clockwise. Switch knob control light will come on. Knob will spring back out when released. Adjust temperature by turning knob between positions 2 and 3.

Heater off:

The clockwork in the temperature regulating switch switches the heater off automatically after about 10 minutes and the lamp goes out.

To switch off before clockwork has run down:

Turn temperature regulating switch anti-clockwise to 0. The lamp goes out and clockwork runs down.

Engine running

Heater on –

Turn knob clockwise to position 2. Switch knob control light will come on. Adjust temperature by turning knob between positions 2 and 3.

Heater off –

Turn switch knob counter-clockwise to position 0. Switch knob control light will go out.

Notes

■ Every time the heater is switched off, the warm air and combustion air blowers continue running briefly to cool the heater down quicker.

■ To avoid draining the battery, do not run the heater repeatedly when the engine is not running.

■ When the heater is running on the clockwork time switch, it must be switched off by hand before attempting to start the engine at low temperatures so that the full battery capacity is available to turn the engine.

Maintenance

During the winter and when driving over very poor roads, mud or snow may tend to accumulate in the exhaust and combustion air intake pipes. Have these pipes checked for blockage from time to time so that the heater can continue to work.

WARNING

Never start the heater or let the engine or the heater run in an enclosed, unventilated area. Exhaust fumes from the engine or the heater contain carbon monoxide, which is colorless and odorless. Carbon monoxide, however is a very harmful gas, and may be fatal if inhaled.

Due to the risk of fire the heater must not be used when vehicle is parked for instance on dry grass or leaves.

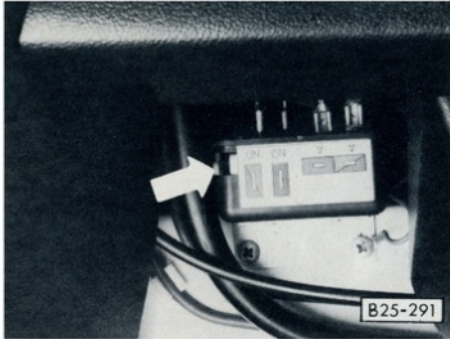

Fuses

The auxiliary heater is equipped with two fuses, one 16 amp fuse for the entire heater and one 8 amp fuse for the overheating switch. Both fuses are located in a fuse holder behind the glove compartment. When the fuse for the overheating switch is blown, the fan is working however no heat is delivered.

If the replacement fuse blows again, have the heater checked by your VW dealer.

Troubleshooting

The heater has a safety switch which is located under the dash on the left near the steering column. If the heater does not start, or starts and then stops again, wait 3 minutes and then operate the red lever on the safety switch.

If the heater still does not work or if the safety switch stops it again, there is a defect in the heater which can only be repaired by a VW workshop.

OPERATING CONTROLS

SLIDING ROOF*



To **open** pull crank handle out of recess and turn counter-clockwise.

To **close** turn crank handle clockwise.

The sliding roof is locked in any position.

WARNING

For safety reasons, always fold the crank handle back into its recess.

INTERIOR LIGHTS

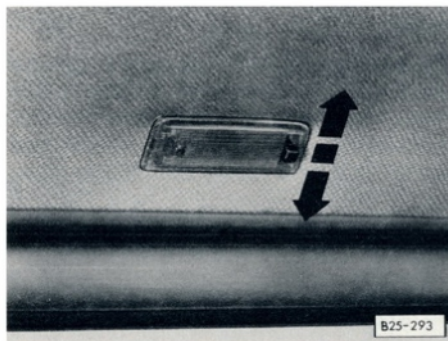

Switch positions

Front interior light:

- Up – ON – with front doors open
- Center – OFF
- Down – ON – with front doors closed

Rear interior light:

- Up/front – ON – with sliding door open
- Center – OFF
- Down/rear – ON – with sliding door closed

CIGARETTE LIGHTER



■ Push knob in.
When lighter is ready for use, it will spring back.

The socket of the cigarette lighter may be used for 12 volt appliances with maximum consumption of up to 100 watts, such as hand spot light, small vacuum cleaner, etc.

ASHTRAYS

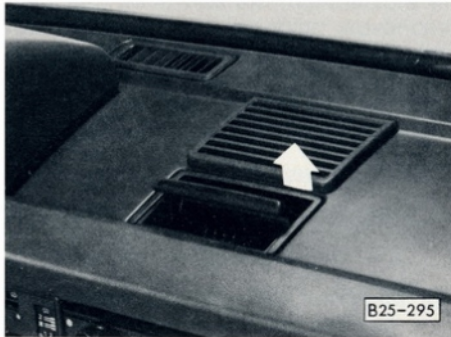

To **remove** ashtray from **dashboard**, grip the strip on opened lid and lift at one side to take out.

To **replace**, move ashtray lid to closed position and press into housing.

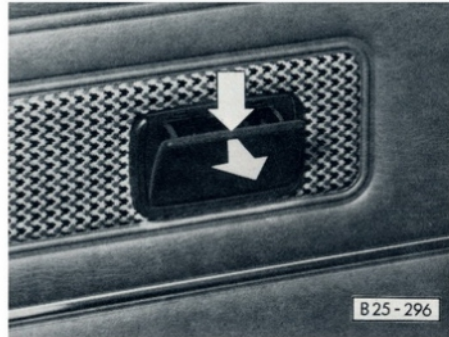

To **remove** **passenger compartment** ashtray, open tray, press down and pull out.

To **replace**, first insert upper edge, and then slide ashtray all the way into housing.

WARNING

Never use ashtrays as waste paper receptacles . . . fire hazard.

GLOVE COMPARTMENT

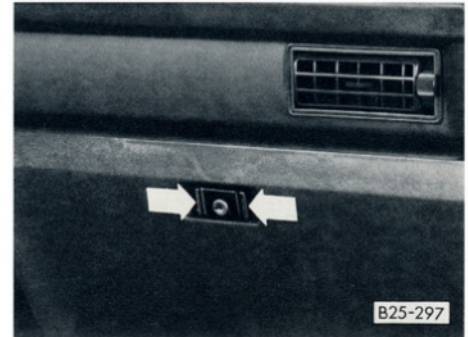

To open

– Squeeze the two lock latches together

To close

– Press door upward until lock engages

To lock or unlock*

– Turn key to right or left

WARNING

Keep glove compartment door closed while driving to prevent injury during a collision.

OPERATING CONTROLS

SUN VISORS

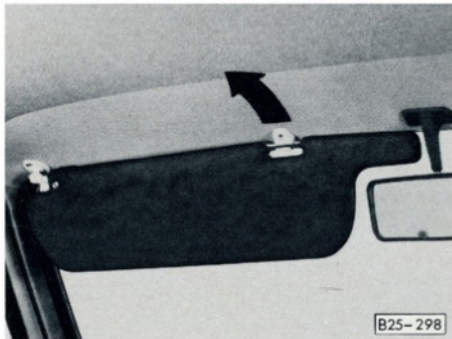

You can lift the visor on the driver's side out of the center mounting and move it toward the door window to protect against side glare.

ASSIST HANDLES/COAT HOOKS

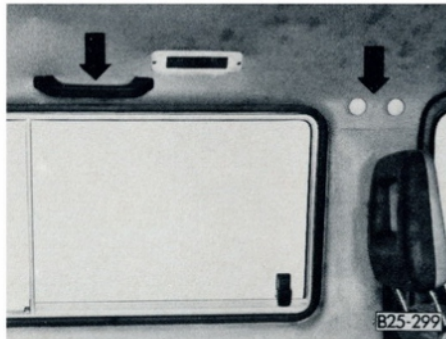

Assist handles and coat hooks are intended for your convenience.

WARNING

- Hang clothes in such a way that they do not impair the driver's vision.
- Do not hang heavy objects on the coat hooks or assist handles, as they could become striking objects in the event of a sudden stop.

OPERATE YOUR VEHICLE SAFELY

A lot has gone into the manufacture of your Volkswagen, including advanced engineering techniques, rigid quality control and demanding inspections. These engineering and safety features will be enhanced by you, the safe driver,

- who knows the vehicle and all controls
- who maintains the vehicle properly
- who uses driving skills wisely.

The following points are important for your safety, please observe them all.

First things first . . .

- Turn the engine off before you attempt any checks or repairs on the vehicle.
- Be sure tires are inflated correctly. Check for damage and tire wear.
- See that wheel bolts or nuts are properly tightened and not loose or missing.
- Check engine oil level, add if necessary. Make it a habit to have engine oil checked with every fuel filling.
- Check coolant level to assure sufficient engine cooling.
- Be sure you have a well charged battery.
- Check brake fluid level. If too low, have brake system checked.
- Replenish windshield washer fluid.
- Replace worn or cracked wiper blades.
- See that all windows are clear and unobstructed.
- Check whether all light lenses are clean.

- Be sure all lights are working and headlights are aimed correctly.

- Check under vehicle for leaks.

- Be sure all luggage is stored securely.

You'll find helpful hints on how to perform most of these checks in this manual. If in doubt, have these checks performed by your dealer or any other qualified mechanic.

Emergency equipment

It is good practise to carry emergency equipment in your vehicle. Some of the things you should have are: window scraper, snow brush, container or bag of sand or salt, emergency light, small shovel, first-aid kit, etc.

In the driver's seat

- Check operation of horn.
- Position seat for easy reach of controls.
- Adjust inside and outside rear view mirrors.
- Use safety belts as directed.
- Check operation of foot and parking brakes.
- Check all warning and indicator lights when starting the engine.
- Do not leave vehicle idling unattended.
- To prevent inadvertent opening of doors from inside or outside drive with locked doors.

On the road

- Always drive defensively. Expect the unexpected.
- Use signals to indicate turns and lane changes.
- Turn on headlights at dusk.
- Always keep a safe distance from the vehicle in front of you, depending on traffic, road and weather conditions.
- Reduce speed at night and during inclement weather.
- Observe speed limits and obey road signs.
- If you smell gas fumes in the vehicle, drive with the windows open, but keep the rear lid closed. Have the cause immediately located and corrected.
- When tired get well off the road, stop and take a rest. Turn the engine off. Do not sit in the vehicle with engine idling. Engine exhaust is dangerous if inhaled.
- When stopped or parked, always set the parking brake. Move the selector lever to "P" (Automatic transmission) or move the gearshift lever to reverse or first gear (Manual transmission). On hills also turn the wheels toward the curb.

- When stalled or stopped for repairs, move the vehicle well off the road. Turn on emergency flasher and use other warning devices to alert other motorists. Do not park or operate the vehicle in areas where the hot exhaust system may come in contact with dry grass, brush, fuel spill or other flammable material.
- Make it a habit to have the engine oil checked with every fuel filling.

BREAK-IN PERIOD

The internal friction in a new engine is high. It will diminish gradually as all moving parts adjust to each other. You can contribute to extending the service life and economy of your engine by observing the following precautions.

During the first 600 miles/1000 km:

- Full throttle should be avoided.

Manual Transmission		
Gear	up to 600 miles	up to 1000 km
1	12 mph	20 km/h
2	25 mph	40 km/h
3	44 mph	70 km/h
4	65 mph	105 km/h
Automatic Transmission		
Driving positions	up to 600 miles	up to 1000 km
Gasoline engine:		
D	69 mph	110 km/h
2	47 mph	75 km/h
1	22 mph	35 km/h

From 600 miles/1000 km to 900 miles/1500 km the speed can be gradually increased.

VEHICLE OPERATION

AFTER BREAK-IN PERIOD

After the break-in period, the following speeds should not be exceeded:

Manual Transmission		
Gear	after 900 miles	after 1500 km
1	16 mph	25 km/h
2	31 mph	50 km/h
3	50 mph	80 km/h
4	top speed	top speed

Automatic Transmission		
Driving positions	after 900 miles	after 1500 km
D	top speed	top speed
2	54 mph	87 km/h
1	33 mph	53 km/h

DURING AND AFTER BREAK-IN PERIOD

Applies to all vehicles:

■ Details on how to operate Manual and Automatic transmission are outlined in the "Operating controls" chapter.

■ **Avoid full throttle starts and abrupt stops.**

■ **Try to avoid running the engine at maximum speed – changing up early helps to save fuel and reduces noise.**

■ **Do not overstrain engine; select proper gear or driving position before reaching top speeds.**

■ **Do not let engine labour – change down when engine no longer runs smoothly.**

■ All speeds are only valid when engine is properly warm.

■ Always observe local and national speed limits.

Applies in addition to vehicles with Automatic Transmission:

Make it a habit to accelerate gradually instead of using full throttle. During gradual acceleration the transmission shifts earlier into the next higher gear thus saving fuel.

OPERATE YOUR VEHICLE ECONOMICALLY

We made great efforts to make your vehicle fuel efficient. However, fuel economy will vary depending on where, when and how you drive, on the optional equipment installed and on the condition of your vehicle.

- Keep a light foot on the accelerator.
- Drive smoothly, avoid abrupt changes in speed as much as possible.
- Avoid jack rabbit starts and sudden stops.
- Avoid unnecessary idling. Turn the engine off.
- “Warm up“ idling wastes gas. Start the engine just before you are ready to drive. Accelerate slowly and smoothly.
- Do not drive longer than necessary in the lower gears. By shifting up early you can economize on fuel consumption.

- Organize your trips to include in several errands.

- Any additional weight carried in the vehicle reduces fuel economy. Always keep cargo to a minimum and remove all unnecessary items.

- Remove roof and ski racks when not in use.

- All electrical consumers contribute to increased fuel consumption. Therefore, use fan, rear window defogger, etc., only when needed.

- Check your vehicle's fuel consumption regularly. Keep a written tally sheet or use the trip odometer. Fuel consumption will vary with traffic, road and weather conditions.

- If average fuel consumption seems to increase, have the vehicle inspected. A well tuned and properly maintained vehicle will help you maintain optimum fuel economy.

- Air cleaner should be inspected to assure proper engine “breathing”.

- Battery should be fully charged.

- Wheels should be properly aligned.

- Tires should be inflated to correct pressures.

- The published EPA mileage estimates may vary, depending on speed, weather and trip length. Your actual highway mileage will probably be less.

- Have the engine oil level checked with every fuel filling. Engine oil consumption is normal but tends to be higher when the engine is new. The use of quality engine oil and a correct engine oil level are essential for vehicle performance and economical operation at all times.

FUEL SUPPLY

Vehicles with catalytic converter require unleaded fuel with a minimum octane rating of 91 RON.

An embossed reminder sticker is on the dashboard cluster, and another sticker is located next to the fuel filler cap.

Such vehicles have a smaller fuel tank opening, and gas station pumps have smaller nozzles. This will prevent accidental pumping of leaded fuel.

Deposits from leaded gasolines destroy the catalytic converter and thus defeat its purpose to control exhaust emissions.

Unleaded fuels may not be available outside the continental U.S. and Canada. Therefore, we recommend you do not take your vehicle to areas or countries where unleaded fuel may not be available.

Vehicles without catalytic converter can be driven with regular fuel, including low-lead or unleaded fuel with a minimum octane rating of 91 RON.

Octane rating

Octane rating indicates a gasoline's ability to resist detonation. Therefore, buying the correct octane gas is important to prevent engine "knock", which reduces performance and may cause engine damage.

Under high load operating conditions, high test unleaded gasoline may be used.

The 91 RON octane rating which you will find on the inside of the fuel tank flap is based on the research method. The CLC octane rating usually displayed on U.S. gasoline pumps is calculated as follows: Research octane number plus motor octane number, divided by 2.

Regular fuels have an octane rating ranging from 91 to 95 **RON** (Research Octane Number) or 87 to 91 **CLC** (U.S. Cost of Living Council Octane rating).

Do not use any fuel with octane ratings lower than 91 RON or 87 CLC.

Gasolines containing alcohol

Gasoline containing alcohol is available at gas stations in some areas. The gas pump may not be labeled to identify that alcohol is present in the gasoline. If it is labeled, it may not identify what amount and type(s) of alcohol are used. We recommend you **DO NOT** use fuels where the alcohol content cannot be identified.

Gasolines containing methanol

DO NOT use fuels containing methanol (methyl alcohol, wood alcohol). The use of fuel containing this type of alcohol can result in vehicle driveability and performance problems and may damage original parts of your vehicle's fuel and emission control systems.

**Genuine VW Parts:
The people who built
your VW
used them.
And so should you.**



There are only Genuine VW Parts in your new VW. That's one reason why it runs like a new VW.

No one knows your new VW in quite the same way as the people who built it. And when it comes to replacement parts, we build them to the same standards and specifications as the original equipment. We've made sure that these genuine replacement parts are built with the same enduring quality that you would look for in a new VW.

To be sure you're getting the best in genuine replacement parts for your VW, ask your dealer about the Autobahn line of parts. It's a convenient way of choosing from among the most popular maintenance and replacement parts with the kind of quality that you want to put in your automobile.

Shown on the opposite page are just a few of the genuine replacement parts available at our parts department. We'll be glad to help you select the right ones for your car.

And they are backed by our Limited Parts Warranty. Even after your New Car Warranty has run out and you have a repair performed, our Limited Parts Warranty ensures that we will repair or replace every defective Genuine VW Part, used in the repair, for 6 months or 6,000 miles, whichever comes first.*



FUEL TANK CAPACITY

Gasolines containing ethanol

A mixture of unleaded gasoline and ethanol (ethyl alcohol, grain alcohol) is sold in some areas. The mixture is sometimes called "Gasohol". You may decide to use gasohol in your Volkswagen, provided it contains no more than 10 % ethanol, and the octane requirements for your vehicle are met. However, we strongly recommend to switch back to gasoline without ethanol.

If you experience any of the following problems with your vehicle:

- Deterioration of driveability and performance.
- Substantially reduced fuel economy.
- Vapor lock and non-start problems, especially at high altitude or at high temperatures.
- Engine malfunction or stalling.

Continued use of gasohol under these conditions may cause costly damage to the fuel system and the emission control system of your vehicle.

The capacity of the tank is 16.0 gal/60 liters (Reserve is 2.5 gal/10 liters of total capacity).

The fuel filler neck is located above the right front wheel.

CLEANING PRODUCTS

Any automobile is subjected to abuse from industrial fumes, corrosive road salt, abandoned lollipops, muddy dog feet, etc.; to name just a few. A well cared for VW can look like new many years later. Regular and correct care will contribute to maintaining the beauty and the value of your VW.

Your VW dealer has a number of car-care products and can advise you which ones to use for cleaning the exterior and interior of your vehicle.

Whether you use VW recommended products or other, commercially available cleaning agents, make sure first of their correct application.

WARNING

- Cleaning agents may be poisonous. Keep them out of the reach of children.
- Observe all caution labels.
- Always read directions on the container before using any product.
- Most chemical cleaners are concentrates which require dilution.
- Do not use gasoline, kerosene, naphtha, nail polish remover or other volatile cleaning fluids. They may be toxic, flammable or hazardous in other ways. Only use spot removing fluids in well ventilated areas.

EXTERIOR

Washing and waxing

The paint on your VW is very durable but must be protected from losing its luster due to outside influences. Therefore, wash and wax your VW often. The longer the dirt is left on the paint, the greater the risk of damaging the glossy finish, either by scratching if the dirt is rubbed into the paint, or simply by the chemical effect dirt particles have on the paint surface.

Do not wash or wax in direct sunlight. Do not use hot water. Lukewarm to cool water is kinder to the paint.

WARNING

- Do not wash, wax or dry the vehicle with the engine running.
- Do not clean the underside of chassis, fenders, wheel covers, etc., without protecting your hands and arms. You may cut yourself on sharp-edged metal parts.
- Moisture and road salt on brakes may affect braking efficiency. Test the brakes after each vehicle wash.

Use plenty of water, a car-wash and wax solution and a soft sponge or hose brush. Begin by spraying water over the dry surface to remove all loose dirt before applying the car-wash and wax solution. Use plenty of water to rinse the vehicle off. Wipe everything dry with a chamois to avoid water spots.

To guard against corrosion from inside out, clean drain holes on the bottom of doors, tail gates, hatches, etc., after each washing. Then wipe dry thoroughly. Also inspect all weatherstrips to make sure they do not allow water to enter the body panels.

Do not aim the water jet directly at door, hatch or rear lid locks. Tape the key holes to prevent water from seeping into the lock cylinders. Water in lock cylinders should be removed with compressed air. To prevent locks from freezing in the winter, squirt glycerine or lock de-icer into the lock cylinders. **Do not use any solution that can damage the body paint.**

The underside of the vehicle picks up dirt and road salt used to keep streets and highways free of snow and ice. To guard against corrosion, it is important to remove mud, debris and road salt from the underside with a powerful jet of water. Be sure to include the wheel housings, bumpers, muffler, tailpipe and brackets. This should be done twice a year and is best accomplished after the vehicle has been driven through a heavy rain. Let engine and exhaust cool down before washing.

Waxing is not really needed when you have used a car-wash and wax solution. If you do not use a car-wash liquid with wax, apply wax to preserve the natural shine of the body paint. To obtain a long lasting finish, apply hard wax. Wax again when water remains on the surface in large patches instead of forming beads and rolling off.

Use a polish when it becomes evident that waxing no longer accomplishes the job. If the polish you are using does not contain wax, apply hard wax after polishing.

Tar or oil

Do not allow tar or oil to remain on the paint. Remove as soon as possible with a cloth soaked with a special paint cleaner. If you do not have a tar or oil remover, you may substitute with turpentine. After applying a cleaning fluid, always wash with a lukewarm soap water solution and apply a new wax coat.

Insects

Remove as soon as possible with a lukewarm soap water solution or insect remover.

Tree sap

Do not allow tree sap or bird droppings to harden on the paint. Remove with a lukewarm soapwater solution.

Touch-up paint

Your VW dealer has touch-up paint for minor scratches and stone chips. Scratches should be touched up soon after they occur to prevent corrosion. If corrosion formation becomes visible, however, a simple touch-up job will not suffice. The affected surface must be smoothed with sand paper and covered with an anti-rust primer, before restoring the painted finish.

Windows

Keep silicone sprays off the windshield to avoid wiper smear in rain.

Clean all windows regularly to remove road film and car-wash wax buildup. Use a lukewarm soap water solution or an alcohol base commercial window cleaning agent. If a chamois is used for polishing the glass, it should exclusively be used for that purpose.

To assure that windshield washers and rear window washer* also function at freezing temperatures, anti-freeze must be added to the washer fluid reservoirs beforehand. It is advisable to use window washer solvent with anti-freeze all year round. Follow directions on the can for the right amounts to be used. **Do not use engine coolant anti-freeze or any other solution that can damage the paint.**

Wiper blades

Always loosen frozen wiper blades from glass as they may tear otherwise. Remove all wiper blades periodically and clean them thoroughly with an alcohol base cleaning solution. Use a sponge or soft cloth and wipe lengthwise.

Weatherstrips

To seal properly, weatherstrips around hood, hatch, windows, doors, etc., must be pliable. Spray with silicone or coat with talcum powder or glycerine to retain flexibility of the rubber and to protect against freezing in the winter.

Dull finishes and plastics

Plastic parts, such as light bulb lenses, decorative stripes, panels, bumpers, etc., will come clean with regular washing. Should additional cleaning or spot removal be necessary, use a soft brush or cloth soaked with a mild detergent solution. Then rinse thoroughly and immediately with clear water.

Do not use anything which could mar the plastic or dull finished surface such as wax, polish, abrasive detergents or chemical cleaning solvents.

Sliding door

The sliding door mounting points, the guide tracks and the roller guides should be lubricated regularly and as often as necessary.

Bright metal trim

Bright or black anodized trim will come clean with regular washing. To protect metal trim, use car wax. Remove spots or dirt from chrome and stainless steel with a chrome cleaner. Apply a chrome polish for continued luster and protection.

Light alloy wheels

To preserve the decorative appearance of the light aluminum cast, some special care is necessary. Aside from road dirt and salt sprays, brake metal dust will exert corrosive effects. If left on too long, brake metal dust can cause pitting. Wash the wheels with a sponge or hose brush every other week. Road salt should be removed weekly with an acid free cleaning solution. Every three months (after regular cleaning) the wheels should be coated with petroleum jelly or car wax. Rub it in firmly with a soft cloth. Never use abrasive or metal polishing cleaning agents.

Remember that moisture and road salt on brakes may affect braking efficiency. Test the brakes after each washing.

INTERIOR

Glass

Use the same cleaning agents as for exterior and polish dry.

Fabric

Use a vacuum cleaner or a soft bristle brush to remove dust and loose dirt from carpeting, upholstery, headliner and other trim. Dirt stains can usually be removed with a lukewarm soap water or all purpose cleaner solution, or a dry foam cleaner. For greasy, oily and other stubborn stains, use a spot remover. Do not pour the liquid on the fabric. Dampen a clean cloth and rub carefully, starting at the edge and working inward.

Plastic and vinyl

Use a clean, damp cloth or sponge to keep this trim free from dust. For other soilage, use a lukewarm all purpose cleaning solution or a mild saddle soap for vinyl trim. Remove water spots and soap traces with a clean, damp cloth or sponge. Use a clean, soft cloth to rub dry.

Grease, tar or oil stains can be removed with a clean cloth or sponge soaked with all purpose cleaner or with a solvent type vinyl cleaning agent.

CORROSION PROTECTION

Seat belts

Keep belts clean. Very dirty belts may not retract properly. Do not remove belts from the vehicle to be cleaned. Do not use chemical cleaning agents, bleach or dyes. They contain corrosive properties which will weaken the webbing. Do not allow inertia reel safety belts to retract before they are completely dry.

For cleaning, use a mild soap water solution. Let belts dry out thoroughly and away from direct sun light.

The engine compartment, as well as all engine, transmission, front and rear axle assembly surfaces have been treated at the factory with a wax based coating for protection against corrosion.

WARNING

Do not apply additional undercoating or rustproofing on or near the exhaust manifold, exhaust pipes, catalytic converter or heat shields. During driving, the substance used for undercoating could overheat and cause a fire.

Engine Compartment

If it becomes necessary to steam clean or otherwise wash the engine compartment, the wax based protective coating is usually lost. It is therefore important to reapply this protective coating to all engine compartment panels, flanges, cavities, seams and engine assembly surfaces.

Chassis

The lower body shell of your VW is thoroughly protected against corrosion. However, it is recommended to have the underside inspected twice a year. Any detected damage to the undercoating, due to road hazards, should be repaired promptly. Oil based protective sprays must not be applied. Only tar or wax based anticorrosion protectors are compatible with the factory applied undercoating. Before application, road dirt, salt spray deposits and oily substances must be removed.

Whenever the lower body shell, axle, transmission or engine assemblies have been repaired, the lost anticorrosion coating of the affected surfaces should be renewed.

Let your VW dealer advise and assist you.

LUBRICANTS

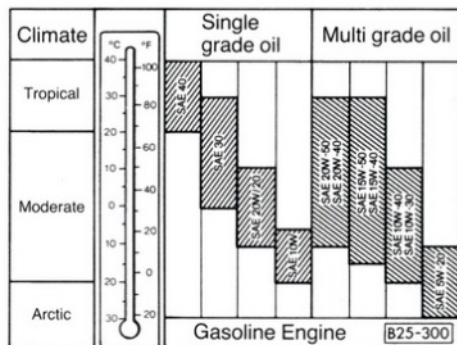

Engine

Always use quality oil/petroleum based and/or synthetic based. The terms "API Service SE or SF" must appear on the oil container singly or in combination with other designations.

Engine oils are graded according to their viscosity. The proper grade to be used in your engine depends on existing climatic or seasonal conditions.

Refer to the temperature chart when selecting engine oil. As temperature ranges of the different oil grades overlap, brief variations in outside temperatures are no cause for alarm. It is also permissible to mix oil of different viscosities if you find it necessary to add oil.

When using SAE 10 W or SAE 5 W–20 engine oil, avoid high speed long distance driving if outside temperature rises above the indicated limits.

Oil change intervals specified in the Maintenance booklet accompanying the vehicle apply to normal operating conditions and must be adhered to, including intervals for oil filter change.

If your drive mostly short distances, or if you operate the vehicle in dusty areas, or under predominantly stop-and-go traffic conditions, or when temperatures remain below freezing for extended periods, the engine oil should be changed more frequently.

Transmission

Manual transmission:

Hypoid-oil SAE 80, SAE 75W/80 or SAE 80W/90 (Mil-L-2105 or API/GL 4).

Automatic transmission:

ATF Dexron® for torque converter and SAE 90 or SAE 80W/90 (Mil-L-2105B or API/GL 5) for final drive.

Power steering

ATF Dexron®

Lubricant additives

Volkswagen does not recommend the use of oil additives.

Battery

Silicone spray or petroleum jelly should be used for the battery terminals and posts.

EXERCISE EXTREME CAUTION WHEN WORKING ON THE ENGINE

The engine compartment of any motor vehicle is a potentially hazardous area. If you are not fully familiar with proper repair procedures, do not attempt the adjustments described on the following pages. This caution applies to the entire vehicle.

WARNING

- Before working on any part in the engine compartment, turn the engine off and let it cool down sufficiently. Hot engine compartment components can burn skin on contact.
- Be alert and cautious around engine at all times while the engine is running.

- If work has to be done with the engine running, always set the parking brake, and make sure the shift lever is in either Neutral or Park.

- Exercise extreme caution to prevent neckties, jewelry or long hair from getting caught in the fan blades, the V-belts, or any other moving engine parts.

- Do not smoke or allow an open flame around fuel or battery.

- Keep a fire extinguisher in close reach.

- Always support your vehicle with safety stands if it is necessary to work underneath the vehicle. The jack supplied with the vehicle is not adequate for this purpose.

- When working underneath the vehicle without safety stands but with the wheels on the ground, make sure the vehicle is on level ground, that the wheels are blocked and that the engine cannot be started. Remove the ignition key.

- Incomplete or improper servicing may cause problems in the operation of the vehicle. If in doubt about any servicing, have it done by your VW dealer or any other properly equipped and qualified workshop.

- Improper maintenance during the warranty period may affect your warranty coverage.

ENGINE OIL

Engine oil consumption

It is normal for your engine to consume oil. The rate of oil consumption depends on the quality and viscosity of oil, the speed at which the engine is operated, the climate, road conditions as well as the amount of dilution and oxidation of the lubricant.

Because of these variables, no standard rate of oil consumption can be established, but drivers should expect an increased oil consumption at high speeds and when the engine is new.

■ **The engine in your vehicle depends on oil to lubricate and cool all of its moving parts. Therefore the engine oil should be checked regularly and kept at the required level.**

■ **Make it a habit to have the engine oil level checked with every fuel filling.**

■ **Lack of sufficient engine oil may lead to severe engine damage.**

■ **The oil pressure warning light is not an oil level indicator.**

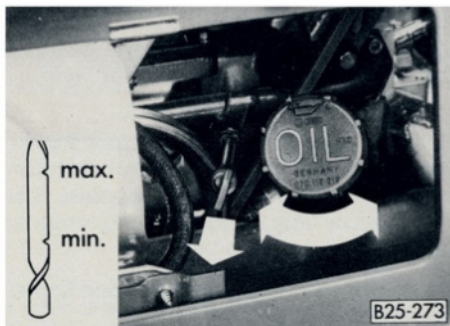

The engine oil dipstick and the oil filler neck are located behind the license plate lid.

Checking the engine oil level

- Turn off the engine.
- To get a true reading, the vehicle should be on level ground. After turning off the engine, wait a few minutes for the oil to return to the crankcase.
- Flip license plate down.
- Pull out dipstick and wipe it clean with a rag.
- Reinsert dipstick; push it in all the way for an accurate reading.
- Pull dipstick out again. The oil level is correct if it is between the “max” and “min” marks on the dipstick.
- If oil level is below “min” mark, or not showing on dipstick, add oil immediately.

Adding engine oil

- Unscrew cap from oil filler neck.
- Pull extension tube out of filler neck as far as it will go.
- Only add the amount of oil needed. Always select a quality oil with the correct specification. See “Lubricants” on page 56.
- The difference between the “min” and “max” marks on the dipstick is about 1 U.S. quart or 1 liter.
- Push in the extension tube, replace filler cap and hand tighten securely.
- Check oil level with dipstick.

WARNING

The oil filler cap must be secure to avoid oil spill causing fire hazard.

Changing the engine oil

Have your engine oil changed regularly, but at least twice a year (see Maintenance booklet).

This is very important as the lubricating properties of oil diminish gradually during normal operation of the vehicle.

If you drive mostly short distances, or if you operate the vehicle in dusty areas, or under predominantly stop-and-go traffic conditions, or when temperatures remain below freezing for extended periods, the engine oil should be changed more frequently.

Because of the detergent additives in the oil, the fresh oil will look dark after the engine has been running for a short time. This is normal and there is no reason to change the oil more often than recommended by the manufacturer.

- Turn off the engine.
- Allow the oil to drain when the engine is warm.

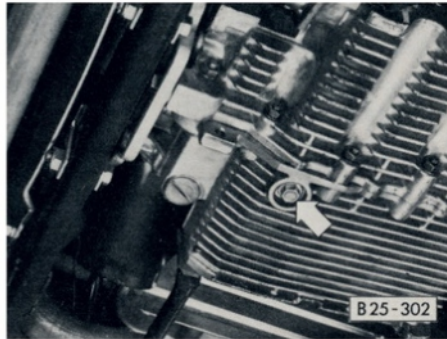

- Remove the oil drain plug (arrow) fully.
- Fill the engine with oil. **Do not overfill.** Always check engine oil level with dipstick as described on previous page.

Engine oil capacity is listed under "Capacities", page 90.

WARNING

- When turning oil drain plug with your fingers, keep your arm as high as possible. This will prevent hot oil from running down your arm. Wear eye protection.
- On the gasoline engine, always use a new gasket when reinstalling the plug. Do not overtighten the plug.

Be mindful of how you dispose of used engine oil. Do not dump it on garden soil, wooded areas, into open streams or down sewage drains.

Local zoning ordinances or environmental regulations will tell you how you can dispose of it. Should the discarding of the old oil present a problem to you, we suggest you have the oil changed at your dealer or a service station.

Always heed WARNINGS on page 57.

ENGINE OIL FILTER

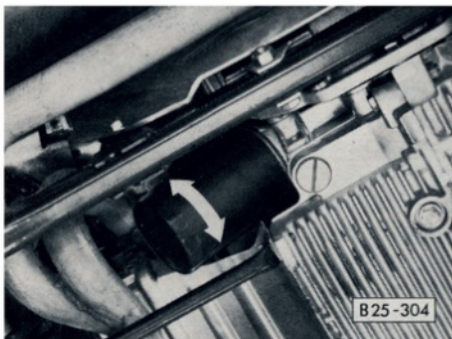

- Run engine at various speeds for three to five minutes and check for leaks.
- Check dipstick for correct oil level, top up if necessary.

Changing the oil filter

The oil filter should be changed at the intervals listed in your Maintenance booklet.

- Remove old oil filter element and discard.
- **Use only Oil filter part No.: 070115561 as otherwise engine damage can occur.**
- Lightly coat seal of new filter element with oil.
- Screw on filter element and hand-tighten according to manufacturer's instructions on the carton or on the filter element.
- Fill engine with appropriate amount of engine oil.

Always heed WARNINGS on page 57.

AUTOMATIC TRANSMISSION FLUID / MANUAL TRANSMISSION OIL

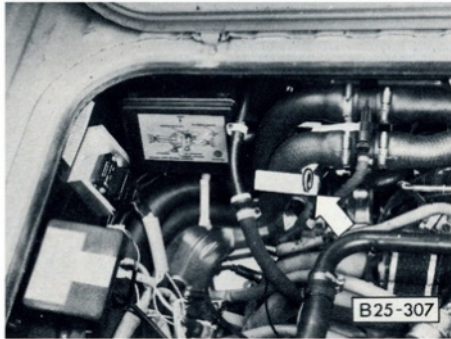
**Automatic Transmission Fluid**

The torque converter and the transmission are lubricated with Automatic Transmission Fluid (ATF).

The final drive requires hypoid oil SAE 90 or SAE 80 W/90, which does not have to be changed.

Checking the ATF level

The ATF has to be checked at frequent intervals, for instance, when the engine oil is being checked or at least at the intervals specified in your Maintenance booklet.

A correct ATF level is very important for transmission operation.

The ATF should be checked when it is warm, with the engine idling, the selector lever in Neutral and the parking brake applied.

WARNING

Checking the ATF level is potentially hazardous because the hot engine has to be running during the check. Do not attempt to check the ATF before reading all WARNINGS on page 57.

The ATF filler neck is in the engine compartment on the left hand side. The dipstick is attached to the plug. Pull it out and wipe it clean first before inserting it to take a reading.

The Automatic transmission may be damaged by even a tiny speck of dirt. Only use lint free rags to wipe the dipstick. Use a clean funnel or spout when adding ATF.

You have enough ATF if the fluid level is between the two marks on the dipstick. It should never be above or below these marks. If level is too high or too low do not just add or drain ATF. Have your dealer check and correct the cause as soon as possible.

For correct ATF specifications, see "Lubricants" on page 56.

Changing the ATF

The ATF has to be changed at the intervals specified in your Maintenance booklet.

Do not tow the vehicle or run the engine without ATF in the transmission.

Manual Transmission Oil

Both transmission and final drive are combined in one housing. The lubricant used is hypoid oil which does not have to be changed.

Always heed WARNINGS on page 57.

AIR CLEANER

A dirty filter element not only reduces the engine output but can also cause premature engine wear.

Normally, it is not required to service the air cleaner more often than recommended in the Maintenance booklet. If the vehicle is driven on very dusty roads, the air cleaner must be serviced more frequently, even daily.

The paper filter element must never be cleaned or soaked with gasoline, cleaning fluids or oil.

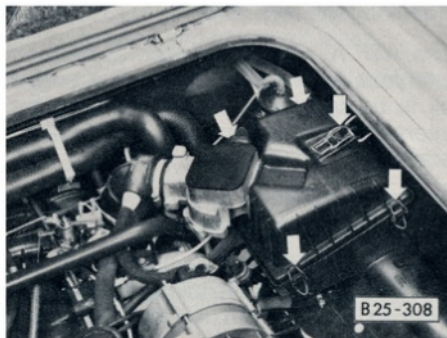

- Turn off the engine.
- Unfasten clamps and pull top of air cleaner housing toward you.
- Lift out filter element.
- Shake filter element to remove dirt. Replace if necessary.
- Reinstall filter element in top.
- Press top onto lower part of filter housing and fasten clamps.

POWER ASSISTED STEERING*



With the engine running, the fluid level in the power assisted steering system must be checked at regular intervals. If fluid level drops below the “**Max**” mark on the reservoir in the engine compartment, add ATF Dexron. Hand tighten the red filler cap securely.

WARNING

If the engine is not running, power assisted steering is no longer effective. You can continue to steer the vehicle; however, more effort will be required to turn the steering wheel.

COOLING SYSTEM

The cooling system is sealed and generally requires little attention.

For year round driving, anti-freeze is added at the factory for temperatures down to:

- 13° F/-25° C (USA)
- 31° F/-35° C (Canada)

Because of its anti-corrosion properties, anti-freeze should also remain in the cooling system for summer operation.

The coolant level should be checked from time to time, and always before going on a longer trip.

Should you ever notice a loss of coolant have the cause promptly corrected by your VW dealer.

The refill tank and the expansion tank are in the engine compartment.

The coolant level is normally checked only in the refill tank (behind the license plate lid).

The expansion tank needs checking only if a large amount of coolant is lost or if the warning light in the water temperature gauge lights up.

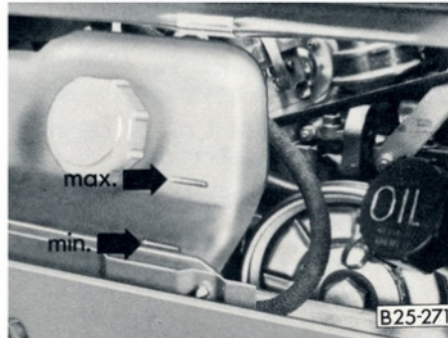

Refill tank

Checking the coolant level

On the refill tank and the expansion tank, the cap need not be taken off, since the tanks are transparent.

On the refill tank, the coolant level must be between the min. and max. marks when engine is cold and not running. When engine is warm, coolant level may be slightly above max. mark.

The expansion tank is equipped with an electric coolant level checking device. When the coolant level is too low, the warning light in the water temperature gauge (see page 30) will flash until the coolant level has been restored to normal.

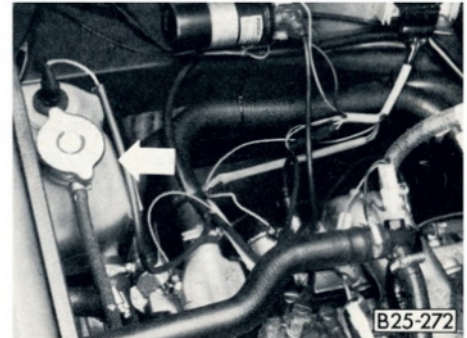

Expansion tank

Adding coolant

WARNING

When the engine is hot, the cooling system is under pressure. Let the engine cool down. If you have to remove the cap from a hot expansion tank, protect your hands, arms and face against scalding. Use a thick rag and carefully turn cap only enough to allow excess pressure to escape. Then slowly remove the cap.

Top up coolant in refill tank. Only when cooling system was drained or a lot of coolant needs to be added, also fill expansion tank.

Always heed WARNINGS on page 57.

To maintain the anti-corrosion properties of the coolant, the anti-freeze concentration should not be reduced, even during the warm season.

Use any quality phosphate-free anti-freeze containing ethylene glycol. Such anti-freeze is available at your VW dealer.

Anti-freeze, other than specified by Volkswagen, may cause corrosion of the cooling system, leading to engine overheating and damage.

Only for topping-up coolant, a small amount of anti-freeze containing ethylene glycol and phosphates may be used, if recommended anti-freeze is not available.

- After adding coolant, run the engine at idle speed for a few seconds.
- Wait for the radiator fan to switch on and off again.
- Check coolant level. Add more coolant if necessary.

Winter operation

At the beginning of the winter season, have the coolant checked for anti-freeze concentration. If you have to add, use any quality phosphate-free anti-freeze containing ethylene glycol which is available at your VW dealer.

The ratio between water and anti-freeze depends on the anticipated outside temperatures.

Increasing the anti-freeze in the coolant further than shown on the container is not only uneconomical, it is also detrimental to engine cooling.

V-BELT

Tension checking

Correct V-belt tension is important for overall vehicle performance, in particular, tension of the V-belt which drives the water pump (see also page 89).

Tensioning and replacing of V-belts vehicle should be performed by your VW dealer or a qualified workshop.

WARNING

Stay well clear of the V-belt when the engine is running. Before checking V-belt tension turn the engine off and let it cool down.

WINDSHIELD / REAR WINDOW WASHER CONTAINER*



The filler cap is located at the left side of the driver's footwell.

Vehicles with rear window wiper and washer have an additional container on the right in the luggage compartment.

To fill the container, unsnap cover and unscrew the filler cap. After filling the container, screw the cap on tightly and close cover.

The capacities of the containers are listed under "Capacities" on page 90.

As clear water is usually not adequate for cleaning the glass, add a cleaning solution to the water.



Use windshield washer solvent with anti-freeze all year round. It helps to keep your windshield and rear window clean and prevents freezing of fluid in the winter.

Do not use engine coolant anti-freeze or any other solution that can damage the vehicle paint.

Follow the directions on the can for the correct amount to be used.

After filling the container press the cap onto the filler neck.

BRAKE FLUID RESERVOIR

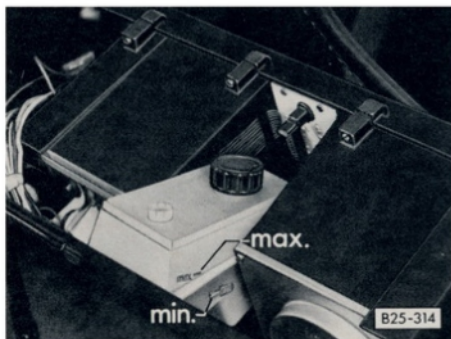

The brake fluid reservoir is located under the instrument cluster in the dashboard panel.

To gain access to the reservoir, grasp the two recesses provided on back of the frame cover and pull up.

When replacing the cover, insert the front edge first, then press the cover down firmly. Make sure it is correctly seated.

The fluid level in the brake fluid reservoir should always be between the two marks "MAX" and "MIN". If the brake fluid level falls considerably below the mark "MIN" the complete brake system should be thoroughly checked by your VW dealer and the cause corrected.

WARNING

■ Every 2 years the brake fluid has to be replaced. See your Maintenance booklet.

■ If brake fluid must be added to the reservoir, use only new and unused DOT 3 or DOT 4 brake fluid that meets SAE specification J 1703 and conforms to Federal Motor Vehicle Safety Standard 116.

■ Do not use any other brake fluid, or brake fluid that has absorbed moisture from the open air, or brake fluid that is dirty. It may cause premature wear or unreliable braking action.

■ Do not add or mix DOT 5 silicone type brake fluid with the brake fluid in your vehicle as severe component corrosion may result. Such corrosion could lead to brake system failure.

■ Brake fluid is poisonous

When adding or replacing brake fluid, make certain to avoid spilling. Brake fluid will damage fabric, paint, plastics and metal. Cover the areas surrounding the reservoir before removing the filler cap.

Always heed WARNINGS on page 57.

BATTERY

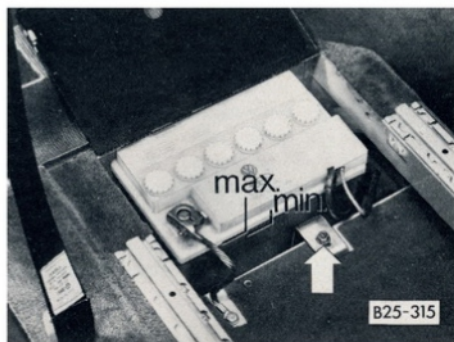

The battery is located under the front passenger seat. To check the battery, move the seat all the way forward.

Electrolyte level

Under normal operating conditions, the battery in your VW is maintenance-free. At high outside temperatures it is advisable, however, to check the fluid level at regular intervals through the transparent battery housing. The fluid level should always be between the “min” and “max” marks in each cell.

If the fluid level is below the “min” mark, let your VW dealer correct the condition.

WARNING

- Do not let battery acid come in contact with skin, eyes, fabric, or painted surfaces.
- If you get electrolyte in your eyes or on your skin, immediately rinse with cold water for several minutes and call a doctor.
- Do not expose the battery to an open flame or electric spark. Hydrogen gas generated by the battery is explosive.

Winter operation

During the winter months, battery capacity tends to decrease as temperatures drop. Additionally, more power is consumed while starting, and the headlights, heater, rear window defogger, etc., are used more frequently. Curtail unnecessary power consumption, particularly in city traffic or when travelling short distances only. Let your VW dealer test the battery's capacity before winter sets in. A well charged battery will not only prevent starting problems but will also live longer.

Always heed **WARNINGS** on page 57.

Cleaning terminals and connections**WARNING**

- Before work is done on the electrical system, disconnect the negative ground strap.
- When working on the battery, be sure not to short circuit the terminals with tools or other metal objects. This would cause the battery to heat up very quickly, which could lead to damage or explosion.

The terminals and connections should be kept clean and greased with silicone spray or petroleum jelly. Make sure the ground connection to the body is tight and free of corrosion.

Never drive the vehicle with a disconnected battery as this may damage the electrical system.

Replacing battery

A replacement battery must have the same specifications as the original equipment battery. Specifications are listed on the battery housing. Make sure the replacement battery can be installed correctly and securely. See “Removing and reinstalling battery” on page 82.

TIRES WHEELS

The original equipment tires and wheel rims on your vehicle comply with all applicable Federal Motor Vehicle Safety Standards.

To maintain these safety standards, remember the following:

- **Wheel rims, wheel bolts or lug nuts are matched to fit your VW.**
- **For technical reasons it is not possible in every case to use wheels from other vehicles – under certain conditions not even wheels from the same vehicle model.**
- **The use of wheel rims, wheel bolts or lug nuts that do not meet specifications of the original factory installed equipment will affect the safe operation of your vehicle.**
- **Before you plan on exchanging steel wheels, light alloy wheels, or winter tires already mounted on wheel rims, consult your VW dealer. He has the technical information necessary to advise you which wheel rims, wheel bolts or lug nuts are compatible with the original factory installations.**

Tire pressures

WARNING

Incorrect tire pressures cause increased tire wear and adversely affect road holding of the vehicle, leading to loss of control.

Required cold tire inflation pressures are listed on a sticker on the left doorjamb.

Use an accurate tire pressure gauge when checking inflation pressures. Do not exceed the maximum tire inflation pressure listed on the tire sidewall. Cold tire inflation pressure means: when a vehicle has not been driven for at least 3 hours or less than 1 mile.

Always include the spare tire during a pressure check.

Tire traction

WARNING

When driving on wet or slushy roads, a wedge of water may building up between the tires and the road. This phenomenon is known as aquaplaning and may cause partial or complete loss of traction, vehicle control or stopping ability. Reduce speed on wet surface.

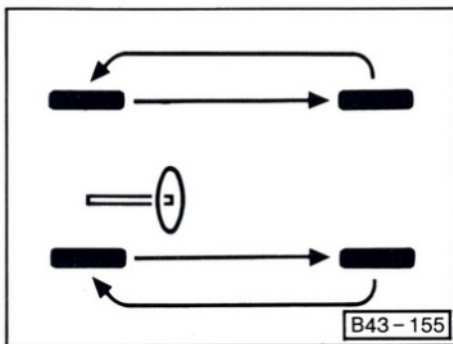

Tire life and rotation

Tire life depends on various factors, i. e. roads, traffic and weather conditions, driving habits, type of tires and tire care.

Inspect your tires at least every 2,000 miles or 3,000 km for wear and damage. If you notice uneven or substantial wear, wheels might need alignment or tires should be balanced or replaced.

Tire manufacturers recommend rotation every 7,500 miles or 12,000 km for radial belted tires. Rotation and balancing, although an expense to you, will prolong tire life. The sketch illustrates how tires should be rotated.

Tires must always remain on same side of vehicle.

After rotation adjust tire pressure and torque wheel nuts diagonally to 123 ft lb/17 mkg. (Please refer to "Changing a wheel" on pages 73–75.)

Tire replacement

In the interest of maximum safety and best all-around vehicle handling, always buy replacement radial tires that have the same specifications with regard to tire size, design, load carrying capacity, tread pattern, tread depth, etc. This also applies to VW recommended alternate replacement tires.

If your tires are worn to the safe limit, replace all 4 tires at the same time. If this is not possible, replace tires in pairs, either front or rear. Do not combine tires of different design, size or tread pattern.

WARNING

- Never mix radial bias belted or bias ply type tires.
- New tires do not possess maximum traction. They tend to be slippery. Break new tires in by driving at moderate speed for the first 100 miles or 160 kilometers.

Tire specifications are imprinted on the sidewall of the tires. If in doubt, check with your VW dealer.

Whenever replacing a tubeless tire, always install a new valve stem. Tire repair should only be performed by a specialist.

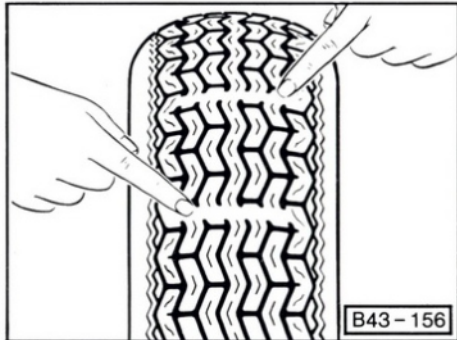

Tire wear

The original equipment tires on your vehicle have built-in wear indicators. They are molded into the bottom of the tread grooves and will appear as approximately $\frac{1}{2}$ inch (12 mm) bands when the tire tread depth is down to $\frac{1}{16}$ of an inch (1.6 mm).

When the indicators appear in two or more adjacent grooves, it is time to replace the tires. We recommend, however, that you do not let the tires wear down to this extent. Worn tires cannot grip the road surface properly, and are even less effective on wet roads.

WARNING

Do not drive with worn tires or tires showing cuts or bruises as they may lead to sudden deflation.

If you notice that tires are wearing unevenly, consult your VW dealer. Uneven wear may not always be due to improper wheel alignment. It can be the result of individual driving habits such as cornering at high speeds. If the tire pressure is not checked and adjusted regularly, abnormal tire wear can also occur.

Tire care

WARNING

■ Avoid damaging tires and wheel rims. If you must drive over a curb or other obstacle, drive slowly and at an angle. Frequently check tires for uneven wear and damage.

■ Remove imbedded material.

■ Replace worn or damaged tires immediately.

■ Replace missing valve dust caps.

■ Keep oil, fuel, brake fluid, etc. away from tires.

■ Keep tires, inflated correctly.

Wheel balancing

A wheel should always be balanced after a tire repair. Even with regular use a wheel can get out of balance, and should therefore be balanced from time to time. Unbalanced wheels may affect vehicle handling and tire life.

Removing and storing tires

The driving direction should be clearly marked on all tires before removing them for storage, to make sure they are remounted and run in the same direction as before. Store tires in a cool and dry place. When remounting put the tires with the most tread depth at the front.

Snow tires

Snow tires are not absolutely essential on vehicles with radial ply tires, because radial ply tires are very good on winter roads.

For a better grip on snow and ice, use all season tires or radial snow tires (M & S) with or without studs. Check with your local Motor Vehicle Bureau for possible restrictions. Because of the special design characteristics of radial ply M+S tires, they should be inflated 3 psi above the cold tire inflation pressures required for the regular radial ply tires. However, do not exceed the maximum tire inflation pressure listed on the tire sidewall. On the all season tires, the inflation pressure does not need to be increased. Snow tires should have the same load capacity as original equipment tires and should be mounted on all four wheels. Snow tires with studs should be run at moderate speeds when new in order to give the studs time to settle.

WARNING

- Tires with badly worn treads and studs are very dangerous. Make sure they are replaced immediately.
- Never mix radial belted or bias ply belted tires.

Do not drive a vehicle equipped with snow tires at prolonged high speed. Snow tires do not have the same degree of traction on dry, wet or snowfree roads as a normal tire. Furthermore, snow tires wear rapidly under these conditions.

Snow tires do not fulfill their purpose if the tread depth is less than $\frac{5}{32}$ in (4 mm).

Snow chains

Snow chains can be used on the rear wheels only.

Check with local authorities for possible restrictions.

Only use chains with fine pitch links protruding no more than $\frac{1}{2}$ in/15 mm from tire tread and side walls, including tensioner. Wheels must rotate freely in all steering positions with chains mounted to prevent damage to body, axle or brake components. Remove chains when roads are free of snow.

DO-IT-YOURSELF-SERVICE

JACK AND TOOLS

The jack and the tools necessary to change a wheel are in a bag stored under the driver's seat.

The screwdriver has a reversible blade.

WARNING

Use the jack only for changing a wheel. Never jack up heavier cars or other loads with it. The car jack must never be used as a support to work underneath the car.

If the jack is accidentally dislodged, you could be seriously injured. When working under the car, always use safety stands specifically designed for this purpose.

SPARE WHEEL

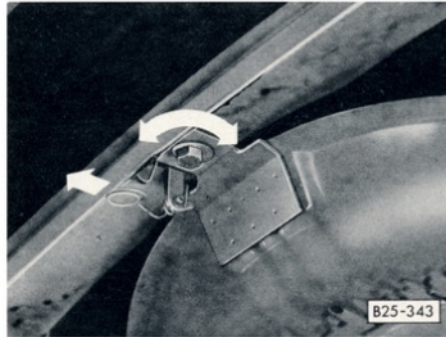

The spare wheel is located underneath the floor panel of the driver cab, where it rests on a hinged metal plate.

■ To take out the spare wheel, remove the bolt (curved arrow) from the holding bracket with wheel wrench.

WARNING

Keep hands and arms away from underbody of vehicle.

■ Stand in front of the vehicle and pull the catch hook (arrow) forward to let the metal plate drop.

■ Pull out the spare wheel.

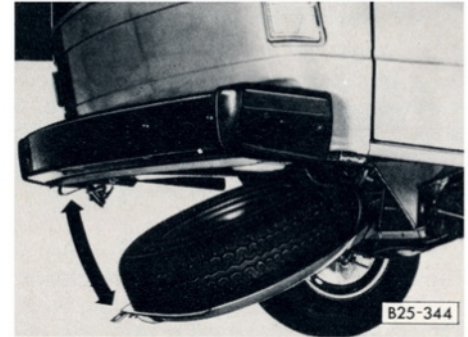

■ When re-installing the spare wheel, slide spare wheel onto metal plate.

■ Give the plate a hard upward push and make sure the catch hook is securely engaged.

■ Replace bolt and tighten firmly.

WARNING

Never drive the vehicle without a firmly tightened bolt on the holding bracket. Should the catch hook disengage accidentally, you could lose control of the car.

Check the inflation pressure periodically to keep the tire ready for use.

CHANGING A WHEEL

WARNING

- If you have a flat tire, move a safe distance off the road. Turn the emergency flasher on and use other warning devices to alert other motorists.
- Passengers must not remain in the vehicle when it is jacked up.
- Before you change a wheel, be sure the ground is level and firm. If necessary, use a board under the jack.
- Set the parking brake and block the wheel opposite the defective wheel on the other side of the vehicle.
- Never jack the vehicle up by the body or the bumpers.



Step 1

- Take out the bag with jack and tools from under the driver's seat.

Step 2

- With the wheels still firmly resting on the ground, remove the hub cap/wheel cover of the defective wheel.

Wheels with wheel cover
(left illustration)

- The wheel cover can be pulled off by hand.

Wheels with hub cap
(right illustration)

- Remove chrome plated hub cap with puller clip and lug wrench. Insert clip in holes at rim of a hub cap. Put wheel wrench through clip, brace one end of wrench on wheel rim and pull lightly on other end.

When you place the hub cap face down, you can use it as a tray for lug bolts (front wheels) or lug nuts (rear wheels).



Step 3

■ Loosen wheel nuts or bolts counterclockwise about one turn with the lug wrench. **Do not yet remove the nuts or bolts.**

To loosen – turn counterclockwise

To tighten – turn clockwise

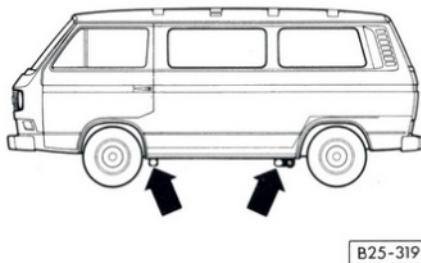

Step 4

There are two jack ports on each side under the car body for front and rear wheel changing.

WARNING

■ Jacking at any other place may damage the car or may result in injuries.

■ Provide a firm base for the jack on the ground. If necessary, use a board.

■ Securely insert the jack into the jack port closest to the wheel to be changed.

■ Before inserting jack, clear jack port.

■ Place jack as straight as possible, as shown.

Step 5

Never jack the vehicle up by the bumper or body.

Do not raise the vehicle until you are sure the jack is securely engaged.

Passengers should not remain in the vehicle when the car is jacked up.

■ To raise the vehicle, turn the handle clockwise.

Only raise the vehicle as much as is needed to change a wheel.

Step 6

WARNING

Before installing the spare wheel, accumulated road dirt must be removed from the inside and outside of the wheel nut/bolt holes to assure a secure mount on front hub or rear drum.

■ Fully unscrew wheel nuts or bolts and place them into the hub cap. Take the top nut or bolt off last. Place the spare wheel against the wheel hub and slightly rotate the wheel until a bolt hole in the wheel is in line with a threaded stud in the wheel hub. Reinstall nuts or bolts and tighten them crosswise by hand before jacking the car down.

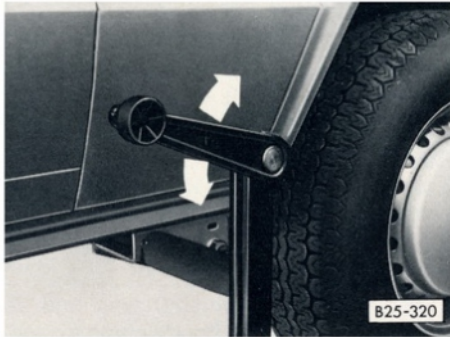

Step 7

- To lower the vehicle, turn the handle counterclockwise.



Step 8

- Then go crosswise from one nut or bolt to another lightening them firmly with the lug wrench.
- **Correct tightness of the wheel nuts is important.**

Correctly tightened nuts or bolts should have a torque of 123 ft lb/17 mkg. This torque can be obtained with the lug wrench by any person of average strength. If in doubt about the correct tightness of the wheel nuts, have it checked with a torque wrench by your dealer or at service station.

Step 9

- To install the hub cap, place it around the lower part of the wheel center. With a firm blow of your hand on the upper part, the hub cap will snap into place. Make sure it is firmly seated.

Step 10

- Fully lower the vehicle and remove jack.
- Correct the air pressure of the tire you have just put on. For correct tire inflation pressures, see the sticker on the left doorjamb.
- Store the jack and tools under the driver's seat.
- Store damaged tire in spare wheel metal plate under front of vehicle.
- Engage lock for metal plate and firmly secure plate with bolt.
- Have flat tire repaired promptly.

DO-IT-YOURSELF-SERVICE

FUSES

A failure in the electrical system may be caused by a burned fuse.

The fuse panel with plug-in arrangement for relays is located under the dashboard on the left hand side of the steering column.

Replacing a fuse

Before replacing a fuse, turn off all lights and accessories and remove the ignition key to avoid damaging the electrical system.

WARNING

When replacing a fuse, do not hold fuse by its metal parts. In case of a repeated short circuit, the new fuse will burn out again, causing possible injury.

- Take cover off.
- Turn all fuses between contact springs until metal fuse strips face upward. In a blown fuse the metal strip is separated. To replace a fuse, simply depress a contact on either side of the fuse.
- Carefully install replacement fuse with metal strip facing upward. The fuse must fit tightly between the contact springs – do not bend the springs.

- Reinstall cover.

If a fuse blows repeatedly, do not keep on replacing it. The cause of the short circuit or overload must be found. On no account should fuses be patched up with tin foil or wire as this may cause serious damage elsewhere in the electrical circuit. It is advisable to always carry a few spare fuses in your car.

Fuse arrangement according to the numbers on fuse panel cover Amp.

1 Tail light left, parking light left, sidemarker light left	8
2 Tail light right, parking light right, license plate light, side-marker light right	8
3 Low beam left	8
4 Low beam right	8
5 High beam left, including indicator light	8
6 High beam right	8
7 Radiator fan	16
8 Interior lights, cigarette lighter, stop lights	8
9 Emergency flasher system (HAZARD) radio	16
10 Windshield wiper/washer pump, blower	16
11 Turn signals	8
12 Horn, back-up lights	8

Additional fuses – in separate fuse holders located at right side of fuse panel

Rear window heating	8
Rear window wiper	8
Auxiliary heater*:	
Entire heater	16
Overheating switch	8

Air conditioner

Two fuse holders with 20 amp and 25 amp fuses for the air conditioning system are located next to the fuse panel under the dashboard to left of steering column.

Color codes

- 8 Amp. fuses – white
- 16 Amp. fuses – red

*where applicable

REPLACING BULBS

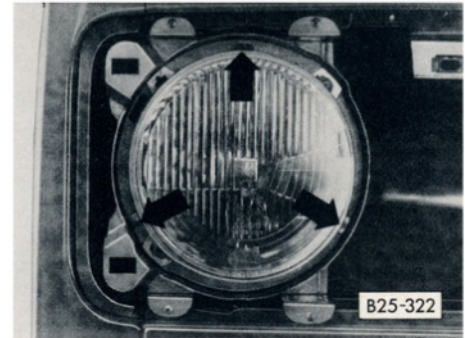
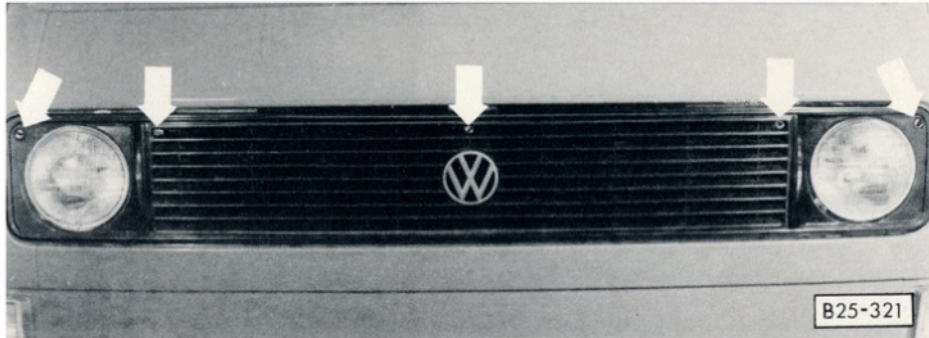

Headlights

Your vehicle is equipped with double filament seven inch sealed beam units.

Should it become necessary to replace a headlight, the air intake grille must be removed first.

- With a screwdriver loosen the five quickrelease screws along upper edge of grille.
- Pull the grille slightly toward you.
- Then lift the grille out of its retainer.

■ Remove the three short screws in the sealed beam retaining ring and take the ring off.

■ Do not alter the position of the long headlight adjustment screws.

■ Take the sealed beam unit out of the support ring and pull the cable connector off.

When installing a new sealed beam unit, be sure the three lugs on the headlight engage properly in the support ring.

If no other headlight part as described here was removed or its position changed, it should not be necessary to aim the headlights. If in doubt have the adjustment checked by your dealer.



Front turn signal / parking light bulb / front side marker light bulb

- Remove the two Phillips screws and take off the lens cover.
- Pull out bulb holder and push down the rubber boot.
- Press spring clip inward and take out bulb holder.
- Give bulb a left turn and remove.
- Replace bulb and reverse the above procedure to install bulb holder and lens cover.

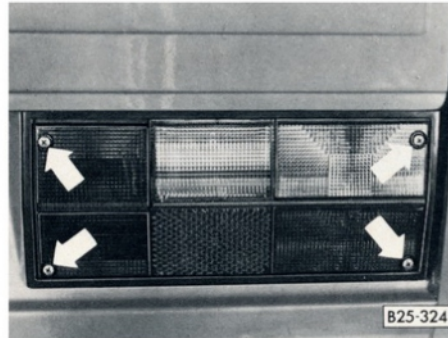

Rear turn signal, stop / tail / back-up light bulb

- Remove the four Phillips screws and take off lens cover with bulb housing.

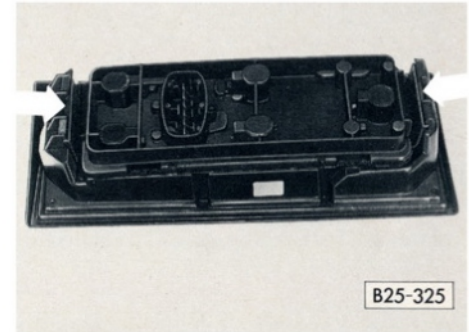

- Squeeze the two side springs inward (arrow) and lift out the bulb housing.
- Press defective bulb into bulb holder, turn left and take out bulb.
- Replace bulb and reverse the above procedure to install bulb housing with lens cover.

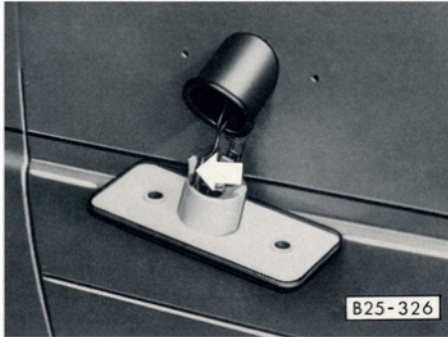

Rear side marker bulb

- Remove the two Phillips screws and take off lens cover.
- Pull out bulb holder and push down the rubber boot.
- Press spring clip outward and take out bulb holder.
- Give bulb a right turn and remove.
- Replace bulb and reverse the above procedure to install bulb holder and lens cover.

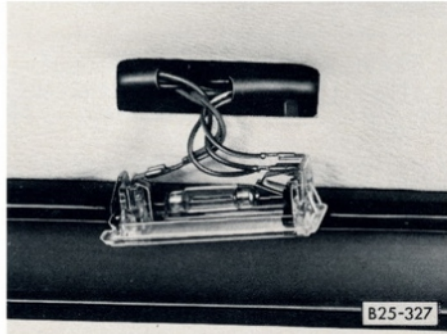

Interior light

- To remove lamp, press against spring clip on left side and lift out the housing.
- Take out bulb from between the two spring contacts and install new bulb.
- Install lamp by inserting switch side of housing into cut-out first.
- Then press in the other side until spring clip engages.

License plate light bulb

There is one bulb housing on each side of the license plate. Only if both bulbs are operative is the license plate properly illuminated.

- Take the bulb housing off by pulling it down.
- Remove the two Phillips screws and take off lens cover.
- Press bulb into housing, turn left and take out.
- Replace bulb and reverse above procedure to install bulb housing and lens cover.

Make sure the spring clip on each side of the housing is securely engaged in the cutouts provided at upper edge of cross panel.

BULB CHART

Always verify part number with your VW dealer

Bulb for	Trade No.	U.S. VW Part No.	Canada VW Part No.
Sealed beam headlights	H 6014	N 191411	N 191411
Front turn signal/parking lights	1034	ZVP 118034	N 177382
Front and rear side marker lights	1816	ZAP 118816	N 177122
Rear turn signal	1073	ZVP 118073	N 177322
Stop/tail lights	1034	ZVP 118034	N 177382
Back-up lights	1073	ZVP 118073	N 177312
License plate light	89	ZVP 118089	N 177192
Interior lights	211	ZVP 118211	N 177232

All dashboard lights, such as illumination of instruments, operating controls, indicator and warning lights, should be repaired if necessary by your VW dealer.

EMERGENCY STARTING WITH JUMPER CABLES

WARNING

■ Improper use of booster battery to start a vehicle may cause an explosion.

■ Lead-acid batteries generate explosive gases. Keep sparks, flame and lighted cigarettes away from batteries.

■ Do not charge a frozen battery; thaw it out first. Gas trapped in the ice may cause an explosion.

■ No attempt should be made to jump start any vehicle with a low electrolyte level in the battery.

■ Make sure, the voltage of both batteries is the same as otherwise the electrical system will be damaged.

■ The capacity (Ah) of the booster battery should not be lower than that of the discharged battery.

■ Vehicle with discharged battery: turn off lights and accessories, remove key, remove lever to **N** or **P** and set parking brake.

■ Vehicle with booster battery should not be running. Disconnect ground cable.

How to use jumper cables

WARNING

To avoid serious personal injury and damage to the vehicle, heed all warnings and instructions of the jumper cable manufacturer. The jumper cables must be sufficiently long for vehicles not to touch.

Improper hook-up of jumper cables can ruin the alternator.

Always connect **POSITIVE (+) to POSITIVE (+), and NEGATIVE (-) to bolt securing ground strap to body.**

1. Connect clamp of plus-cable to positive (+) terminal (1) of discharged battery.
2. Connect clamp on opposite end of cable to positive (+) terminal (2) of booster battery.
3. Connect clamp of minus-cable to negative (-) terminal (3) of booster battery.
4. Connect clamp on opposite end of cable to a bare metal part bolted directly to bolt securing ground strap to body (4) of vehicle with discharged battery. Connect clamp as far away from battery as possible.

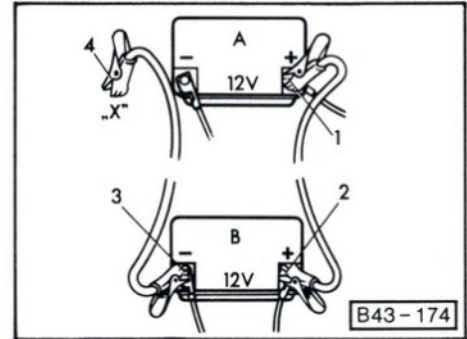

A – Discharged battery

B – Booster battery

X – To bolt securing ground strap to body

5. Start engine in the usual manner. If engine fails to start, do not continue to crank but contact nearest workshop.

6. With engine running, remove jumper cables from both vehicles in exact reverse order: Steps 4 through 1.

Vehicles with Catalytic Converter / Automatic transmission:

Do not push or tow vehicle to start. Damage to the catalytic converter, the transmission and/or other parts of the vehicle may result.

Always heed **WARNINGS** on page 57.

CHARGING OF BATTERY

WARNING

■ Charge battery in a well ventilated area. Keep away from open flame or electrical spark. Do not smoke. Hydrogen gas generated by the battery is explosive.

■ Electrolyte fluid that may spill during charging should be washed off with a solution of warm water and baking soda to neutralize the acid.

■ If you get electrolyte in your eyes or on your skin, immediately rinse with cold water for several minutes and call a doctor.

■ Never charge a frozen battery. It may explode because of gas trapped in the ice. Allow a frozen battery to thaw out first.

■ Never use a fast charger as a booster to start the engine. This may seriously damage the vehicle's electrical system and the charger.

■ Fast charging a battery is dangerous and should only be attempted by a competent mechanic with the proper equipment.

Slow battery charging

WARNING

Heed all WARNINGS and follow instructions that come with your battery charger.

■ It is not necessary to remove the battery from the engine compartment, and it is also not necessary to disconnect the cables.

■ Make sure the electrolyte level in each cell is between the "min" and "max" marks. If the fluid level is below the "min" mark, let your VW dealer correct the condition.

■ Connect charger cables.

Charger cables must be connected POSITIVE (+) to POSITIVE (+) and NEGATIVE (-) to NEGATIVE (-).

Do not connect or disconnect charger cables while charger is operating.

■ Switch on charger.

■ **Charging rate not over 6 Amp.**

Normally, a battery should be charged at no more than 10 percent of its rated capacity.

For example, a charging current of 4.5 Amp. would be used on a battery having 45 Ah. Rated capacity of the battery in your vehicle is listed on the battery housing.

■ After charging, turn off charger and disconnect charger cables.

To remove battery from vehicle

■ Disconnect negative ground strap.

■ Disconnect positive cable.

■ Unscrew bolt of holding plate with open end wrench.

To reinstall battery in vehicle

■ Place battery in vehicle and tighten bolt of holding plate.

■ Reconnect positive cable.

■ Reconnect negative ground strap.

Always heed WARNINGS on page 57.

TROUBLESHOOTING

Your Volkswagen should repay you with troublefree driving if it receives regular maintenance and proper care.

Should you ever encounter difficulties in starting your engine or have trouble on the road, there are a few repairs which you can make to get your vehicle going again.

WARNING

■ If you are not fully familiar with proper repair procedures, do not attempt the checks, adjustments or repairs described on these pages.

■ Move disabled vehicle a safe distance off the road, turn on the emergency flasher and use other warning devices to alert other motorists.

■ Be extremely cautious when working on any part of the vehicle to prevent accidental injury. Remove neckties or necklaces; tie long hair back behind your head. Disconnect the battery ground cable after turning off the engine before working on the electrical or fuel system to prevent sparking. Only connect battery if this is necessary for certain tests.

■ The adjustment of idling and ignition timing requires special equipment and should only be carried out by a VW dealer.

Locate the condition and probable cause of your trouble in the list on the following pages and follow the directions on what to do. If the trouble is serious or if you are uncertain as to its origin, be sure to see a VW dealer or qualified mechanic as soon as possible

Always heed WARNINGS on page 57.

Condition	Probable Cause	What to do
A – Vehicle will not start, engine will not turn over or turns over too slowly.	1. Improper starting procedures. 2. Run down or dead battery. 3. Loose connections: a – at battery b – at starter 4. Starter failure	1. Refer to “Starting procedures” on page 25. 2. Charge or replace battery. Have cause of high power consumption checked. 3. Make sure that all connections are tight: a – check connections at battery and ground strap, retighten as necessary. b – check solenoid connections on starter. 4. Contact nearest VW dealer.

DO-IT-YOURSELF-SERVICE

Condition	Probable Cause	What to do
B – Engine turns over but will not start	<ol style="list-style-type: none"> 1. Improper starting procedures. 2. No fuel in tank. 3. Other failures in ignition or fuel system. 	<ol style="list-style-type: none"> 1. Refer to “Starting procedures” on page 25. 2. Fill up tank. 3. Replace fuse in fuse panel – see “Fuses” on page 76. 4. Contact nearest VW dealer.
C – Engine hard to start.	<ol style="list-style-type: none"> 1. Improper starting procedures. 2. Failure in fuel or ignition system. 	<ol style="list-style-type: none"> 1. Refer to “Starting procedures” on page 25. 2. Contact nearest VW dealer.
D – Engine knocks (pinging).	<ol style="list-style-type: none"> 1. Octane rating of gasoline not correct. 2. Incorrect ignition timing. 	<ol style="list-style-type: none"> 1. Fill up fuel tank with fuel of proper octane rating. See “Fuel supply” on page 50. 2. Contact nearest VW dealer.
E – Engine heats up excessively while driving, water temperature warning light flashes.	<ol style="list-style-type: none"> 1. Stop-and-go or mountain driving in hot weather with air conditioning. 2. Insufficient coolant. 3. Defect in radiator fan or thermoswitch. 4. Insufficient cooling due to fog lights or insect screens (for example) installed on top of front bumper. 5. Ignition retarded. 	<ol style="list-style-type: none"> 1. Slow down. Engine temperature should return to normal. If not, check other probable causes. 2. Add if necessary. 3. Turn the engine off and let it cool down. Contact nearest VW dealer. 4. Remove such accessories. 5. Contact nearest VW dealer.

WARNING

■ Let engine cool down sufficiently. Hot engine compartment components can burn skin on contact.

Condition	Probable Cause	What to do
<p>F – Strong fuel odor while parked or driving.</p> <p>WARNING Never smoke or use an open flame that could ignite fuel vapors.</p>	<p>Leak at fuel cap, fuel lines or fuel evaporation control system.</p>	<p>Turn off the engine. Check fuel cap, all lines and connections. Seal leaks if possible. Contact nearest VW dealer.</p>
<p>G – Strong odor of hot oil.</p> <p>WARNING Do not operate vehicle if engine oil has splashed onto engine compartment components. Fire hazard!</p>	<p>Loose or missing oil filler cap.</p>	<p>Turn off the engine. Have vehicle towed to nearest dealer. Engine compartment must be cleaned.</p>
<p>H – Excessive fuel consumption combined with poor engine performance.</p>	<ol style="list-style-type: none"> 1. Clogged or dirty cleaner. 2. Defect in warm-up unit. 	<ol style="list-style-type: none"> 1. Turn off the engine. Clean or replace air filter element. 2. Contact nearest VW dealer.
<p>I – Engine missing and stalling.</p>	<p>Idle adjustment incorrect, ignition or electrical failure.</p>	<p>Contact nearest VW dealer.</p>

FEATURES

Engine

- Four stroke gasoline engine in rear.
- Four cylinder horizontally opposed.
- Crankshaft with four main bearings.
- Crankshaft with four main bearings.
- Liquid cooling system, thermostatically controlled.
- Thermostat operated electric fan.
- Pressure oil feed with gear – type pump and full flow filter.
- Self-adjusting hydraulic valve lifters.
- AFC (Airflow controlled) fuel injection.
- Paper element air cleaner.
- Exhaust emission control system with activated charcoal filter in the fuel system.
- Breakerless electronic ignition.

Automatic Transmission

- Hydrodynamic torque converter and planetary gearing with three forward and one reverse gear.
- Final drive in separate housing.
- Rear wheel drive, with two constant velocity joints per drive shaft.

Manual Transmission

- Single plate, dry clutch.
- Synchronized four speed transmission and differential in one housing with common lubrication.
- Rear wheel drive, with two constant velocity joints per drive shaft.

Steering

- Rack and pinion
- Safety steering column

Front wheel suspension

- Independent upper and lower control arm
- Stabilizer
- Coil springs
- Shock absorbers

Rear wheel suspension

- Independent semi-trailing arms with integrated axle support
- Coil springs
- Shock absorbers

Brakes

- Hydraulic dual-circuit power-assisted brake system with pressure regulator for rear wheel circuit. Front wheels with disc brakes, rear wheels with self-adjusting drum brakes.
- Parking brake for rear wheels.

Body/Chassis

- All steel unitized body
- Frame plates reinforced with side and cross members.

EMISSION CONTROL SYSTEM

In the interest of clean air

Pollution of our environment has become a problem that is of increasing concern to all of us. We urge you to join us in our efforts for cleaner air in controlling the pollutants emitted from the automobile.

Volkswagen has developed an emission control system that controls or reduces those parts of the emission that can be harmful to our environment. Your VW is equipped with such a system.

Volkswagen warrants the Emission Control System in your new vehicle under the terms and conditions set forth in the Warranty booklet.

Your Volkswagen is equipped with such a system, **which contains the following major components.**

Catalytic converter*

The catalytic converter is an efficient "clean-up" device built into the exhaust system of the vehicle. The catalytic converter burns the undesirable pollutants in the exhaust gas before it is released into the atmosphere.

The exclusive use of unleaded fuel is critically important for the life of the catalytic converter. Therefore, only unleaded gasoline without additives must be used.

The catalytic converter will be damaged by

- **push or tow starting your vehicle**
- **misfiring of the engine**
- **turning off the ignition while the vehicle is moving or**
- **other unusual operating conditions.**

Do not continue to operate your vehicle under these conditions, as otherwise fuel can reach the catalytic converter. This could result in overheating of the converter.

For maintenance intervals refer to your Maintenance booklet.

Oxygen Sensor (OXS)*

The oxygen sensor, installed in the exhaust manifold, continuously senses the oxygen content of the exhaust and signals the information to an electronic control unit.

Every 30.000 miles/48.000 km, the OXS light on the instrument panel will come on and stay on to remind you to take your vehicle to your VW dealer for the scheduled emission control maintenance described in your Maintenance booklet.

Exhaust Gas Recirculation (EGR)*

Some of the exhaust gas from the engine is diverted before it enters the muffler. This gas is routed back into the intake manifold. An exhaust gas recirculation valve controls the flow to the intake manifold. The exhaust gas recirculated into the combustion chambers of the engine helps to lower the formation of oxides of nitrogen (NOx) during the combustion process.

*where applicable

WARNING

To assure efficient operation of the Emission Control System:

■ Have your vehicle maintained properly and in accordance with the service recommendations as described in your Maintenance booklet. Lack of proper maintenance as well as improper use of the vehicle will impair the function of the emission control system and could lead to damage.

■ Do not alter or remove any component of the Emission Control System unless approved by the manufacturer.

■ Do not alter or remove any device, such as heat shields, switches, ignition wires, valves, which are designed to protect your vehicle's emission control system.

■ Do not continue to operate your vehicle if you detect engine misfire or other unusual operating conditions.

Starting

Do not leave engine idling unattended after starting. If warning lights should come on to indicate improper operation, they would go unheeded. Extended idling also produces heat, which could result in overheating or other damage to the vehicle or other property.

Parking

As with any vehicle, do not park or operate your vehicle in areas where combustible materials, such as dry grass or leaves, can come into contact with a hot exhaust system.

Undercoating

Do not apply additional undercoating or rustproofing on or near the exhaust manifold, exhaust pipes, catalytic converter or heat shields. During driving, the substance used for undercoating could overheat and cause a fire.

DATA

Engine

Maximum output SAE net	82 hp at 4800 rpm
Maximum torque SAE net	105 ft lb at 2600 rpm
Displacement	117 CID (1913 cm ³)
Stroke	2.70 in (68.9 mm)
Bore	3.70 in (94 mm)
Compression ratio	7.3 : 1
V-belt	9.5 x 1070 LA
Spark plugs	
Bosch	W7 C 0
Beru	14 L-7C
Electrode gap	0.028 in (0.7 mm)
Battery	Specifications are listed on the battery housing. A replacement battery must have the same specifications as the original equipment battery.

¹⁾ This belt is essential to engine operating. It is advisable therefore to always carry a spare belt in the vehicle to allow prompt replacement

TECHNICAL INFORMATION

Capacities

Fuel tank	16.0 gal/60 liters
Reserve (of total capacity)	2.5 gal/10 liters
Cooling system	18.6 qt/17.5 liters
Engine oil	
with filter change	4.8 qt/4.5 liters
without filter change	4.2 qt/4.0 liters
Automatic transmission fluid ATF	3.2 qt/3.0 liters
Windshield washer container	4.3 qt/4.2 liters
Rear window washer container	1.1 qt/1.1 liters

Dimensions	Station Wagon		Kombi		Camp-mobile	
	in	mm	in	mm	in	mm
Length	179.5	4570	179.5	4570	179.5	4570
Width	72.6	1845	72.6	1845	72.6	1845
Height (unladen)	76.7	1950	77.1	1960	80.7	2055
Overhang, front	42.2	1160	42.2	1160	42.2	1160
Overhang, rear	37.4	950	37.4	950	37.4	950
Wheelbase	96.8	2460	96.8	2460	96.8	2460
Front track	62.3	1583	62.3	1583	62.3	1583
Rear track	64	1570	64	1570	64	1570
Ground clearance with gross vehicle weight	7.4	190	7.4	190	7.4	190
Turning circle diameter	approx. 35 ft/10.7 m (wall to wall)					

Weights

The vehicle capacity weight (max. load), the Gross Vehicle Weight Rating (GVWR), and the Gross Axle Weight Ratings (GAWR) for front and rear, are listed on the Safety Compliance Sticker on the left doorjamb.

The gross vehicle weight rating includes the weight of the basic vehicle plus full fuel tank, oil and coolant, plus max. load which combines passenger (150 pounds/68 kg per designated seating position) and luggage weight. Luggage weight is not increased by the use of a roof rack, unless passenger capacity is reduced accordingly.

The gross axle weight rating is the maximum load that can be applied at each axle of the vehicle.

Roof weights

The maximum permissible roof weight on the station wagon and kombi is 220 lb/100 kg. This load carrying capacity applies to all roof rack installations. The roof luggage rack on the campmobile with pop-up roof allows only 110 lb/50 kg.

WARNING

The actual gross axle weight rating at the front and rear axles should not be exceeded, and their combination should not exceed the gross vehicle weight rating.

VEHICLE IDENTIFICATION

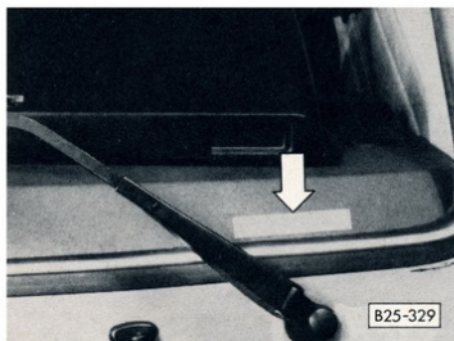

The Identification Number

is located on the instrument panel on the driver's side so that it is visible from the outside through the windshield.

The safety compliance sticker

is your assurance that your new vehicle complies with all applicable Federal Motor Vehicle Safety Standards which were in effect at the time the vehicle was manufactured. You can find this sticker on the left doorjamb. It shows the month and year of complete and incomplete (campmobile only) production and the vehicle identification number of your vehicle (perforation) as well as the Gross Vehicle Weight Rating and the Gross Axle Weight Rating.

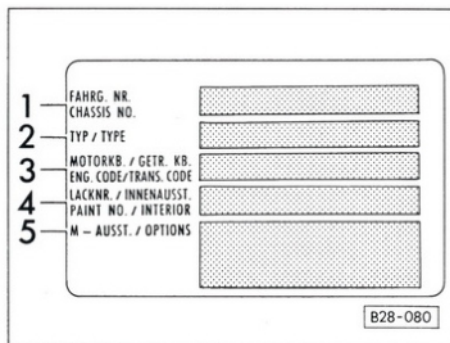

The Vehicle Identification Label

is located on the left side under the dashboard. The label contains the following information:

- 1 Vehicle Identification Number
- 2 Vehicle Code
- 3 Engine and Transmission Code
- 4 Paint and Interior Code
- 5 Option Codes

A duplicate of the label is in your Warranty & Maintenance booklet.



The Engine Number

is located on the right side of the engine block.

EMERGENCY TOWING BY COMMERCIAL TOW TRUCK

Your car can be towed by commercial tow trucks using conventional sling-type gear.

WARNING

Never allow passengers to ride in a towed vehicle for any reason.

Always tow with rear wheels off the ground

This restriction does not apply to cars with manual transmission.

If excessive damage or other conditions prevent towing your car with rear wheels off the ground, use wheel dollies.

GAS STATION INFORMATION

LIFTING VEHICLE

The vehicle should never be lifted or jacked up from underneath the engine oil pan, the transmission housing, or the front or rear axle. This could lead to serious damage.

Lifting with workshop hoist

Make sure there is sufficient clearance between pads and vehicle before driving vehicle on to hoist.

The vehicle must be lifted only at the lift points illustrated.

WARNING

When removing components such as engine block, transmission housing, fuel tank, wheels, front or rear axle, anchor vehicle to hoist or add corresponding weights to maintain the center of gravity. Otherwise the vehicle might tilt or slip off the hoist, causing serious damage or personal injury.

Lifting with floor jack

The same lifting points as illustrated for the hoist also apply when using a floor jack. To avoid damage to the underbody or chassis frame, it is necessary to insert a rubber pad between the floor jack and the lift points.

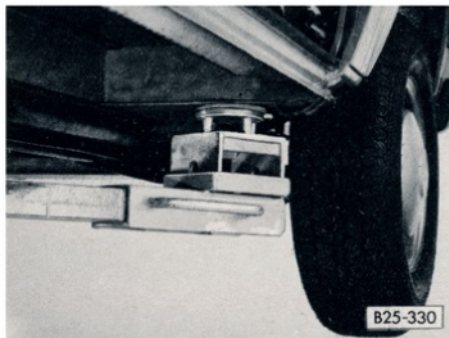

Front

At the front jacking point

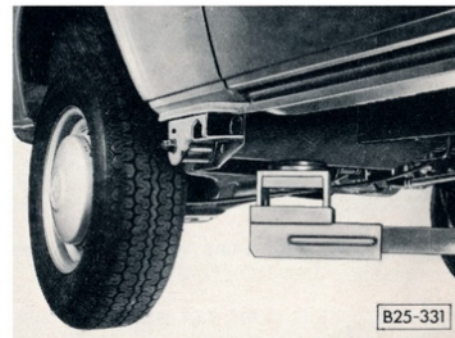

Rear

At rear cross member

Lifting with vehicle jack

WARNING

The vehicle jack must never be used as a support to work underneath the vehicle. If the jack is accidentally dislodged, you could be seriously injured. When working under the vehicle always use safety stands specifically designed for this purpose.

Refer to the "Changing a wheel" on page 73.

STARTING ENGINE

Do not depress accelerator pedal slightly when starting. This applies at any outside and engine temperature.

For more details, see page 25.

Automatic Transmission

Engine will only start with selector lever in Neutral or Park.

Manual Transmission

Start with gearshift lever in Neutral, clutch pedal depressed.

Emergency starting

A vehicle with Automatic Transmission cannot be started by pushing or towing. See page 81 for "Emergency starting with jumper cables".

FUEL SUPPLY/FUEL CAP

REGULAR, unleaded fuel only.

Under high load operating conditions, high test unleaded gasoline may be used.

Gasohol may be used, provided it contains not more than 10 % ethanol.

Do not use any fuel or Gasohol with octane ratings lower than 91 RON or 87 CLC.

Fuel cap — Above right front wheel

The fuel tank has a capacity of 16.0 gal/60 liters including 2.5 gal/10 liters reserve.

GAS STATION INFORMATION

MISCELLANEOUS

Driver's seat

To **adjust seat**, pull lever (1) up.

To **adjust backrest**, push lever (2) down.

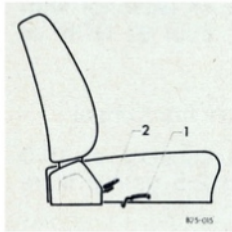

Fuses

On left under dashboard. See page 76.

Tire pressure

See sticker on left doorjamb.

Spare wheel

Underneath floor panel of driver cabin.

Jack and tool kit – under driver's seat.

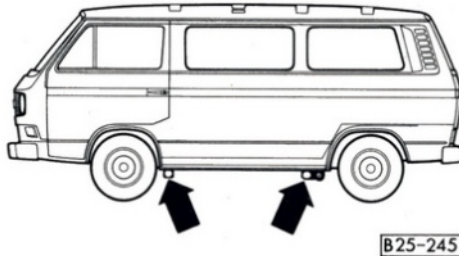

Jack points – two on each side

WARNING

Exercise extreme care when using the jack or when working underneath the vehicle. See warnings on page 72 and 73.

Engine compartment lid

You have access to the engine compartment lid from inside the luggage compartment.

To **open** the lid, roll the floor covering out of the way and turn both lock handles to the left.

To **close** the lid, reverse the above procedure.

WARNING

Before you check anything in the engine compartment, let the engine cool down. Hot components can burn skin on contact. Always heed WARNINGS on page 57.

ATF dipstick*

Check ATF level when ATF is warm, with engine idling, selector lever in Neutral and parking brake applied.

Dipstick has cover plug attached.

Details on page 62.

Brake fluid reservoir

Under instrument cluster. Brake fluid level should be between upper and lower edge of reservoir.

If brake fluid must be added to the reservoir, use only new and unused DOT 3 or DOT 4 brake fluid that meets SAE specification J 1703 and conforms to Motor Vehicle Safety Standard 116. Using any other brake fluid, or using brake fluid that has absorbed moisture from the open air, or brake fluid that is dirty, may cause premature wear or unreliable braking action.

Do not add or mix DOT 5 silicone type brake fluid with the brake fluid in your car as severe component corrosion may result. Such corrosion could lead to brake system failure.

Air cleaner

If the vehicle is driven on very dusty roads, the air cleaner must be serviced between specified maintenance intervals. Details on page 62.

Windshield washer container

– under dashboard left hand side.
Fill with water and cleaning solution.
Follow mixture instruction on can.
After filling, screw on cap tightly.

The container for the rear window washer* is located on the right side in the luggage compartment.

Battery

The battery is located under the front passenger seat.

The electrolyte level should be between MIN. and MAX. marks on battery housing. Check each cell. If the fluid level is below the "MIN" mark, let your VW dealer correct the condition.

GAS STATION INFORMATION

COOLANT REFILL TANK, OIL DIPSTICK, OIL FILLER CAP

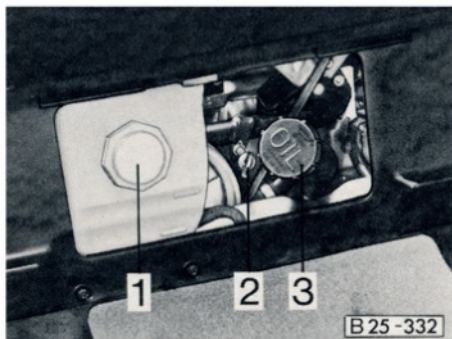

The coolant refill tank, the engine oil dipstick and the oil filler cap are located behind the license plate lid.

1 – Coolant refill tank

Anti-freeze must remain in the cooling system all year round. Coolant level should be between MIN. and MAX. marks on the refill tank when the engine is cold.

Always add anti-freeze and water in ratio specified on container of the antifreeze manufacturer. Use quality phosphate-free anti-freeze containing ethylene glycol.

2 – Engine oil dipstick

Vehicle must be on level ground. Stop the engine and wait at least 5 minutes before checking the oil level. Level should be between upper and lower marks on dipstick. Difference between marks is approx. 1 U.S. qt/1 liter.

3 – Engine oil filler cap

WARNING

The oil filler cap must be secure to avoid oil spill causing fire hazard.

Use quality oil labeled “API Service SE” or “SF”. Oil viscosity charts on page 56.

	page		page		page
Air cleaner	62	Emergency equipment	45	Heating/Ventilation	33
Air Conditioner	36	Emergency flasher	30	High beam	27, 31
Alternator warning light	27	Emergency starting	81	Horn	4
Ashtrays	43	Emergency towing	93		
Assist handles and coat hooks	44	Emission Control System	87	Ignition/steering lock	24
Automatic Transmission	21	Engine compartment lid	9	Indicator lights	26
Automatic Transmission Fluid	61	Engine cooling	28, 63	Introduction	2
Auxiliary Heater	39	Engine exhaust	87	Instrument illumination	30
		Engine number	92	Instrument panel	4
Battery	67	Engine oil changing	59	Instruments	28
Battery charging	82	Engine oil checking	58	Interior light	42
Brake fluid reservoir	66	Engine oil grades	56		
Brake warning light	26	Expansion tank	63		
Brakes	18			Jack and tools	72
Break-in period	47	Fan	28	Jack points	74
Bulb chart	80	Features	86		
Bulb replacing	77	Foreign country driving	3	Keys	6
Buzzer	6, 24	Front seats	11	Kickdown device	23
		Fuel economy	49		
Capacities	90	Fuel gauge	29	Lane changer	31
Catalytic converter	87	Fuel injection	86	License plate lights	79
Cigarette lighter	42	Fuel supply	50	Lifting vehicle	94
Cleaning products	52	Fuses	76	Lights	30, 77
Climate controls	33			Locks	6
Clock	28	Gas Station Information	93	Lubricants	56
Cooling system	63	Gearshift lever	20	Luggage compartment	14
Corrosion protection	55	Glove compartment	43		
				Manual Transmission	20
Defogging/defrosting	34	Headlight dimmer and flasher	31	Manual Transmission Oil	61
Dimensions	90	Headlights	77	Mirrors	10
Do-it-yourself service	72	Headlight switch	30	Miscellaneous	96
Doors	7	Head restraints	14		

ALPHABETICAL INDEX

	page		page		page
Notes to owner	2	Speedometer	28	Warning lights	26
Octane rating	50	Speed ranges	47, 48	Washer reservoir	90
Oil change	59	Starter switch	24	Water temperature gauge	28
Oil filter changing	60	Starting procedures	25	Water temperature warning light	28
Oil pressure warning light	27	Steering lock	24	Weights	91
Operating Controls	4	Stopping engine	25	Wheels	68
OXS (Oxygen sensor)	27, 87	Sunroof	42	Wheel changing	73
Parking brake	19	Sun visors	44	Windows	10
Power assisted steering	62	Switches	30	Windshield washer fluid container	65
Rear lid	9	Swivel seats	12	Windshield wiper/washer lever	32
Rear view mirrors	10	Tail lights	78		
Rear window defogger	30	Technical data	89		
Rear window wiper/washer	32	Technical Information	86		
Refill Tank	63	Temperature gauge	28		
Reverse	20	Tires	68		
Safe driving hints	45	Tools	72		
Safety belts	15	Towing	93		
Safety belts warning light	26	Transmission oil	56		
Safety compliance sticker	92	Trip odometer	28		
Seats	11	Troubleshooting	83		
Secondary heat exchanger	35	Turn signal/headlight dimmer switch lever	31		
Selector lever	21	Undercoating	55		
Side marker lights	78	Unleaded fuel	50		
Sliding door	8, 54	V-belt	65, 89		
Sliding roof	42	Vehicle care	52		
Snow chains	71	Vehicle identification number/label	92		
Spare wheel	72	Vehicle operation	45		
Spark plugs	89	Ventilation/heating	33		
Specifications	89				

© 1983. All rights reserved. May not be reproduced or translated in whole or in part without the written consent of Volkswagenwerk AG. Specifications are subject to change without notice. Printed in Germany 8. 83

000.5620.61.21

www.vag-klassik.de

